

# GlassLink™

dish-to-receiver connection

## Model 1112 For Dual Pane Glass (for single pane use model 1111)

<b>Bandwidth from dish to receiver</b>	950 MHz to 1.45 GHz
<b>Voltage range from receiver to dish</b>	+10.5 VDC to + 21.0 VDC
<b>LNB current range</b>	50 mA to 200 mA*
<b>Operating temperature range</b>	-40° F to + 122° F
<b>Dual pane window thickness range</b>	0.50 to 0.75 inch

(For single pane glass, use Model 1111)



**WARNING:** To prevent electrical shock, do not attempt to service unit. No user-serviceable parts inside.

\* High current LNBs may require use of model 1100 GlassLink™ Power Booster

### Warranty

Multiplex Technology, Inc., warrants this product to be free from defects in materials and workmanship for a period of one year from the date of purchase or MTI will repair or, at its option, replace the defective product. To obtain warranty service, call MTI for a Return Material Authorization (RMA) number and return the product pre-paid accompanied by a copy of the purchase receipt,

Attn: Customer Service. Please put the RMA number on the outside of the carton.

Any implied warranty arising from the sale of the product including implied warranties of merchantability and fitness for purpose are limited to the warranty stated above. MTI shall not be responsible for any loss, damages or expenses, whether direct, consequential, or incidental arising from the use or inability to use this product. Some states do not allow limitations on how long an implied warranty lasts or the exclusion or limitation or incidental or consequential damages, so the above limitations may not apply to you. This warranty gives you specific legal rights, and you may have other rights which vary from state to state.

**Note:** This equipment has been tested and found to comply with the limits for a Class B digital device, pursuant to Parts 15 and 18 of the FCC Rules. These limits are designed to provide reasonable protection against harmful interference in a residential installation. This equipment generates, uses and can radiate radio frequency energy and if not installed and used in accordance with the instructions, may cause harmful interference to radio communications. However, there is no guarantee that interference will not occur in a particular installation. If this equipment does cause harmful interference to radio or television reception, which can be determined by turning the equipment off and on, the user is encouraged to try to correct the interference by one or more of the following measures:

- Reorient or relocate the receiving antenna.
- Increase the separation between the equipment and receiver.
- Connect the equipment to an outlet on a circuit different from that to which the receiver is connected.
- Consult the dealer or an experienced radio/TV technician for help.

**Caution:** Any changes or modifications not expressly approved by the manufacturer of this device could void the user's authority to operate the equipment.

This device complies with part 15 of the FCC rules. Operation is subject to the following two conditions:

- (1) This device may not cause harmful interference and
- (2) This device must accept any interference received, including interference that may cause undesired operation.

multiplex®  
technology, inc.

Post-it™ is a trademark of 3M; GlassLink™ is a trademark of Multiplex Technology, Inc.  
This product is covered by the following patents: US patent number 5612652, ROC patent number 086813  
600-503 B



U.S. and international patents pending.

multiplex®  
technology, inc.

## GlassLink™ Installation

### Part ONE: installation of **OUTSIDE** GlassLink™

1. Using the instructions included with your satellite system, install the dish and locate the satellite receiver in the house.
2. Identify a convenient window, through which the signals from the dish can be routed to the receiver. Usually the GlassLink™ will be located in a lower corner out of sight, but it can be located anywhere, in any orientation, on the glass. Make sure the window uses dual pane thermal glass, ½" to ¾" thick. Contact factory for pane thickness outside this range.
3. Clean the glass thoroughly with glass cleaner. Remove any stickers, paint, decals, heat reflecting films, etc. from the surface of the glass both inside and out. The glass must be perfectly clean and dry. If the glass feels cold to the touch (less than 60° F), use a blow dryer to warm the glass, evaporating any moisture that might be present.
4. Install the **OUTSIDE** GlassLink™ first. Remove the protective papers from the face of the **OUTSIDE** GlassLink™ and press it firmly against the glass. Push on all of the edges to make sure it is seated uniformly all around.
5. Connect the cable from the dish to the **OUTSIDE** GlassLink™. Make sure the cable is properly secured and does not "pull" on the **OUTSIDE** GlassLink™.
6. From the inside, inspect the outside seal. Make sure that it is firm, has no air bubbles, gaps or wrinkles. If there are, go back outside and press until a good, even seal has been achieved.

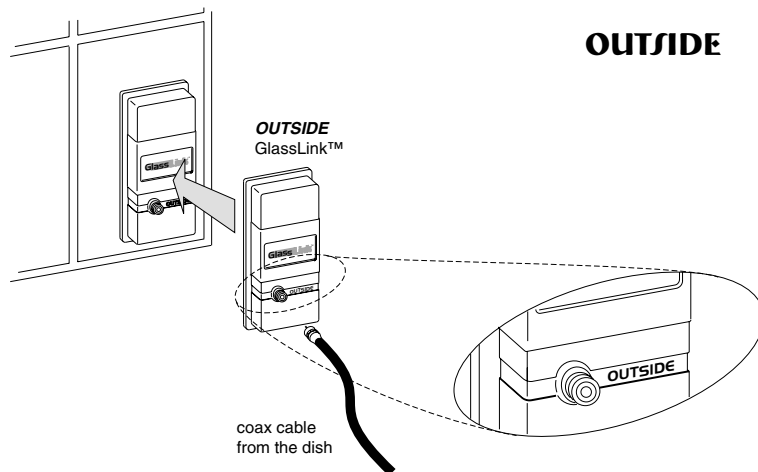

## GlassLink™ Installation

### Part TWO: installation of **INSIDE** GlassLink™

1. It is important that the **INSIDE** GlassLink™ be carefully aligned to the **OUTSIDE** GlassLink™.
2. From the inside, to eliminate a parallax view, look directly through the glass at the **OUTSIDE** GlassLink™. Place the **INSIDE** GlassLink™ on the glass such that:
  - a. The notch of the **INSIDE** GlassLink™ corresponds to the notch of the **OUTSIDE** GlassLink™.
  - b. The outline of the **INSIDE** GlassLink™ is aligned with the outline of the **OUTSIDE** GlassLink™.
3. Once confident that you can repeat this location, remove the protective paper and firmly press the unit into this position.
4. Now attach the cable from the satellite receiver to the **INSIDE** GlassLink™. Make sure the cable is properly secured and does not "pull" on the **INSIDE** GlassLink™.
5. Power up your satellite receiver. LED indicators should be visible on the **INSIDE** GlassLink™. As you change channels on the satellite receiver, you may notice that the LED indicators change color. If the LEDs blink, or there are situations when both LEDs are simultaneously lit, this may indicate the need for the GlassLink™ Power Booster. Call our technical support line at 1-800-999-5225 for additional instructions.

