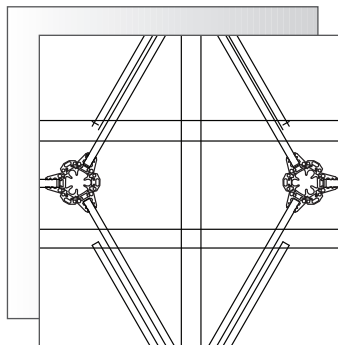
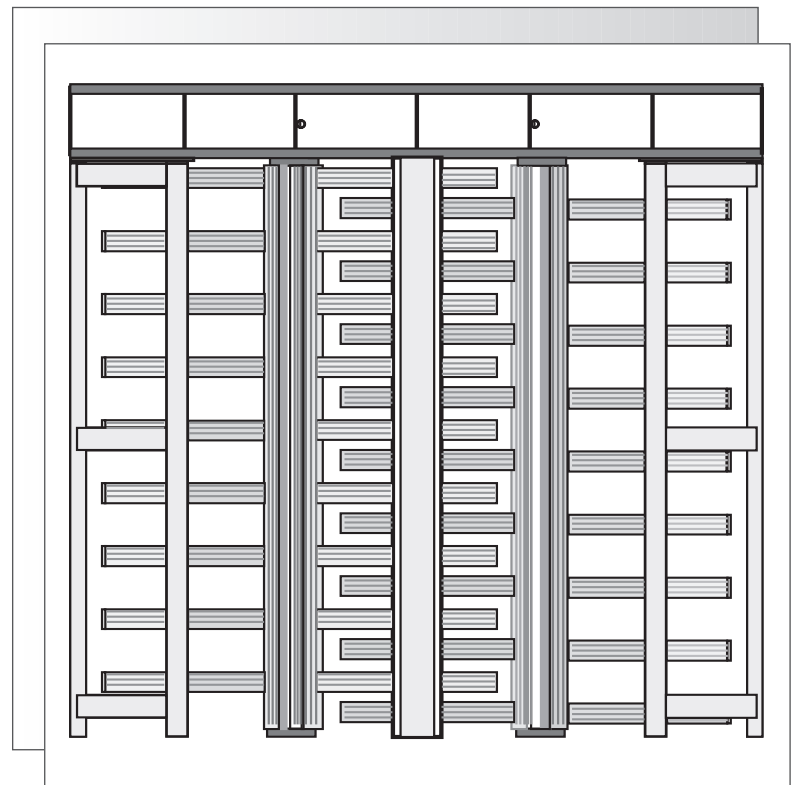
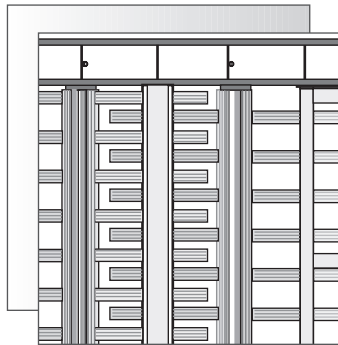
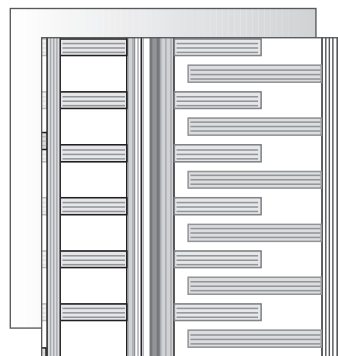


**FULL HEIGHT  
ALUMINUM TURNSTILE  
DOUBLE UNIT**



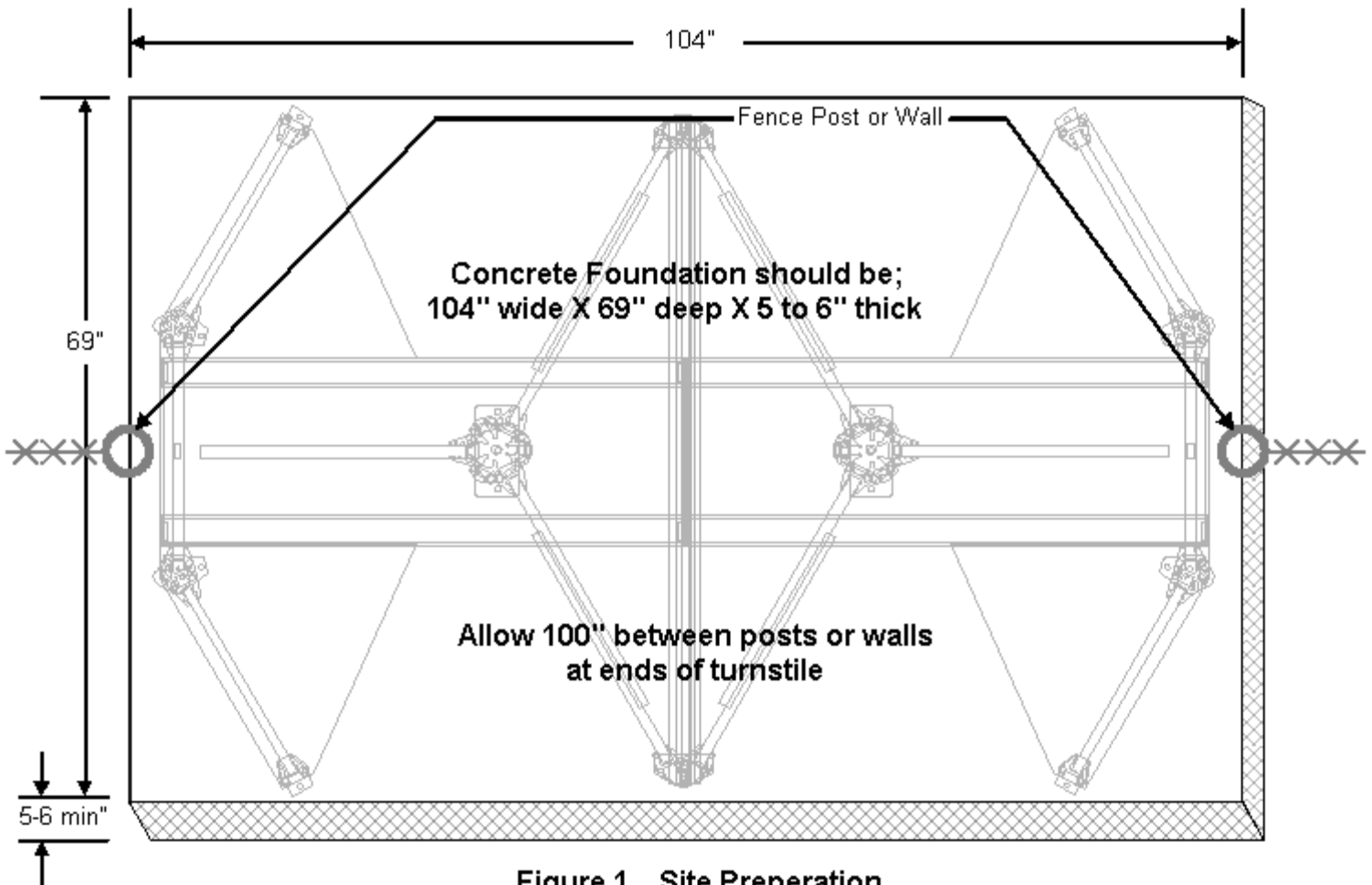
**AT-FAL SERIES**



# CONTENTS

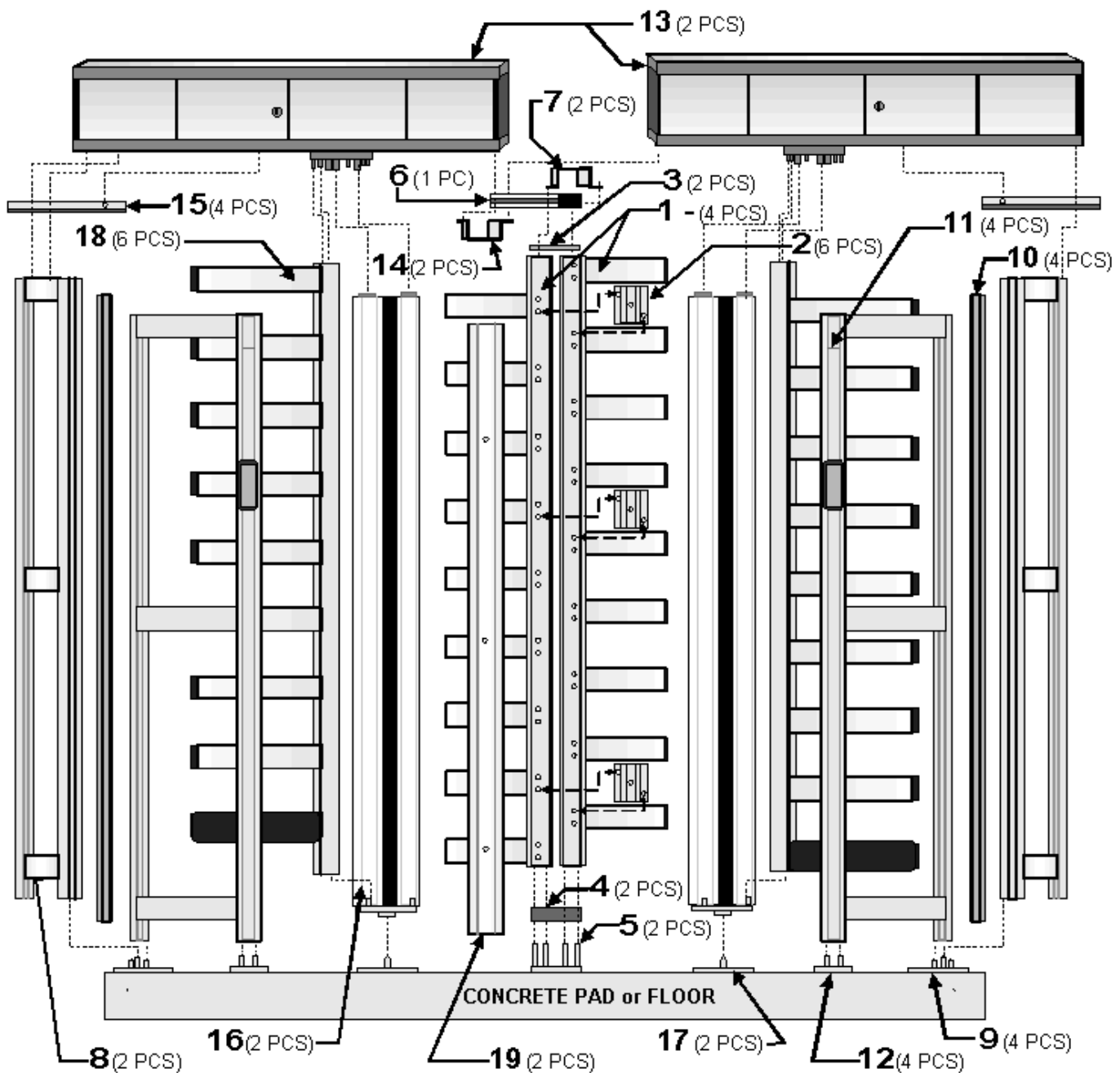
1. SITE PREPARATION
2. EXPLODED VIEW DRAWING
3. UNPACKING
4. SPECIFICATIONS
5. INSTALLATION
6. ELECTRICAL CONNECTION
7. FUNCTIONAL TEST
8. FAIL SAFE OF AIL SECURE CONFIGURATION
9. SERVICE AND MAINTENANCE

## 1 SITE PREPERATION



## 2 EXPLODED VIEW DRAWING (EVD)

NOTE: Where there are multiple identical parts, all are not shown on this drawing for clarity.



- 1 - BARRIER ARM ASSEMBLY
- 2 - BARRIER ANGLE BRACKET
- 3 - BARRIER TOP PLATE
- 4 - BARRIER SPACER PLATE
- 5 - BARRIER MOUNTING PLATE
- 6 - BARRIER CROSS BAR SUPPORT
- 7 - BARRIER CROSS BAR BRACKET
- 8 - CENTER PASSAGE PANEL (CPP)
- 9 - CPP MOUNTING PLATE

- 10 - ANGLE ALIGNMENT EXTRUSION
- 11 - END PASSAGE PANEL (EPP)
- 12 - EPP MOUNTING PLATE
- 13 - HEADER / MECHANISM ASSEMBLY (HMA)
- 14 - HMA MOUNTING BRACKET
- 15 - CEILING PLATE
- 16 - CENTER COLUMN (CC)
- 17 - CC MOUNTING PLATE
- 18 - SPINDLE ARM ASSEMBLY
- 19 - BARRIER BOLT COVER

Figure 2

### 3 UNPACKING

The Turnstile is packaged to allow the installer to work out of the crate as the installation progresses. Check to insure that the following parts are included for the applicable turnstile ordered:

NOTE: The following list is shown in the order that they will be required for installation.

<b>BOX MOUNTING AND INSTALLATION HARDWARE</b>		
<b>Quantity</b>	<b>Description</b>	<b>Part # on Drawing</b>
2	Barrier Mounting Plate	5
2	Barrier Spacer Plate	4
6	Barrier Angle Bracket	2
2	Barrier Top Plate	3
2	Barrier Cross Bar Bracket	7
2	HMA Mounting Bracket	14
4	CPP Mounting Plate	9
4	EPP Mounting Plate	12
2	CC Mounting Plate	17
14	3/8" X 3-3/4" Anchor Bolt w/ Washer and Nut	N/A
8	5/16-18 X 3/4" Header Mounting Bolt w/ Washer	N/A
24	5/16-18 X 3/4" Spindle Arm Assembly Bolt	N/A
24	Bolt Cover	N/A
8	1/2-13 X 3/4" Ceiling Plate and Barrier Top Plate Bolt	N/A
4	1/4-20 Nylock Nut	N/A

<b>INDIVIDUALLY WRAPPED COMPONENTS</b>		
<b>Quantity</b>	<b>Description</b>	<b>Part # on Drawing</b>
1	Barrier Arm Assembly	1
1	Barrier Cross Bar Support	6
2	Center Passage Panel (CPP)	8
4	Angle Extrusion	10
11	End Passage Panel (EPP)	11
2	Header & Mechanism	13
2	Center Column (CC)	16
4	Passageway Ceiling Panel	15
6	Spindle Arm Assembly	18
2	Barrier Bolt Cover	19

## 4 SPECIFICATIONS

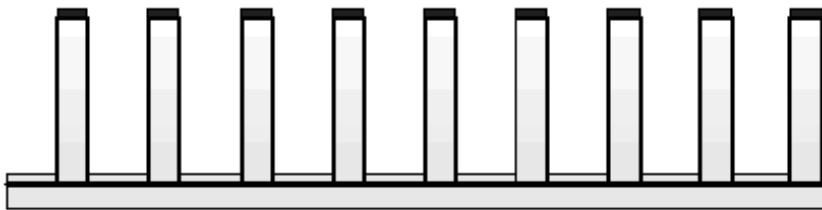
Power	115 VAC @ 3W
Footprint	Double Spindle 63"w X 58"d
Solenoids	24VDC @ 14W
Control Boards	<p>20 VAC INPUT, 5A Contacts            Independent controller for each Direction of Turnstile Rotation            Fail-safe / Fail-secure Switch            Processor Control Logic            Input: Momentary (1 sec or less) Dry Contact closure            Auto Re-Lock when not in use</p>
Passageway	<p>29"w X 80"h Clear Passage            Anodized Aluminum Frame with Clear Polycarbonate Scratch-resistant Panels            Auto-Alignment Extrusions for Positive Position Location            No Gaps between Panels</p>
Spindle Section	<p>Full Height Center Column with Positive Alignment for Arm Sections            Decorative Filler Extrusions between Spindle Arm Sections</p>
Spindle Arm Section	<p>9 Arms Pre-assembled and Locked into Vertical Retainer            Auto Position and Locking Locator Pin Holes, Top and Bottom</p>
Barrier Section	<p>9 Arms Pre-assembled and Locked into Vertical Retainer</p>
Ceiling Plates	1/8" Anodized Aluminum Plates Prevent Crawl Over
Header and Cover	<p>Provided in Sections for ease of Assembly            Sliding, Lockable Access Panels            Access for Removal of Control Mechanism</p>
Control Mechanism	<p>8" O.D. X 1-1/8"h Ratchets            1-1/2"w X 1"h Pawls            Shock Absorbing Bushing in Ratchets and Pawls            Shock Absorbing Mounting for Mechanism            Linear Acting Self-centering            Hydraulic Energy Absorber at end of each Spindle Cycle            Self-aligning Solenoids            Quick Change Configuration (fail-safe or fail-secure)</p>
Weight	1,830 Lbs. (831.8kg)

## 5 INSTALLATION

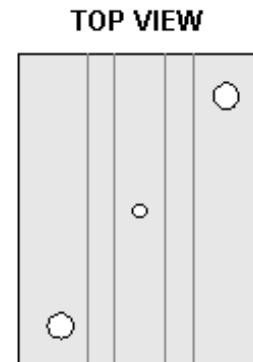
NOTE: FOLLOW THE BELOW INSTRUCTIONS CLOSELY. THE ORDER OF INSTALLATION AND ASSEMBLY IS CRITICAL TO A SUCCESSFUL INSTALLATION.

- REMOVE AND ASSEMBLE THE BARRIER ARM ASSEMBLIES (PARTS #1 and 2 ON EVD)
- IDENTIFY PARTS

NOTE: The Barrier Arm Assembly and Spindle Arm Assembly look similar. The BARRIER ARM ASSEMBLY does NOT have a rubber Heal Protector on one of the arms.



**Figure 3**  
**Barrier Arm Assembly**



**Figure 4**  
**Barrier Angle Bracket**

- ASSEMBLE BARRIERS;
- Position two Barrier Arm Assemblies (Part #1 on EVD) next to each other with the arms varied in distance from the end as shown.

1. Remove the third bolt from the Low End (second arm from the end) and the second bolt from the High End (first arm from the end) as shown in figure 5a at right.
2. Take one Barrier Angle Bracket (Part # 2 on EVD) and position it to where the holes line up with the holes on the Barriers where the two bolts were just removed.
3. Replace the bolts through the brackets and tighten very tight.
4. Repeat steps 1, 2 and 3 on the eleventh bolt from the Low End (sixth arm from the end) and the tenth bolt from the High End (fifth arm from the end).
5. Repeat steps 1, 2 and 3 on the eleventh bolt from the Low End (ninth arm from that end) and the sixteenth bolt from the High End (eighth arm from that end).

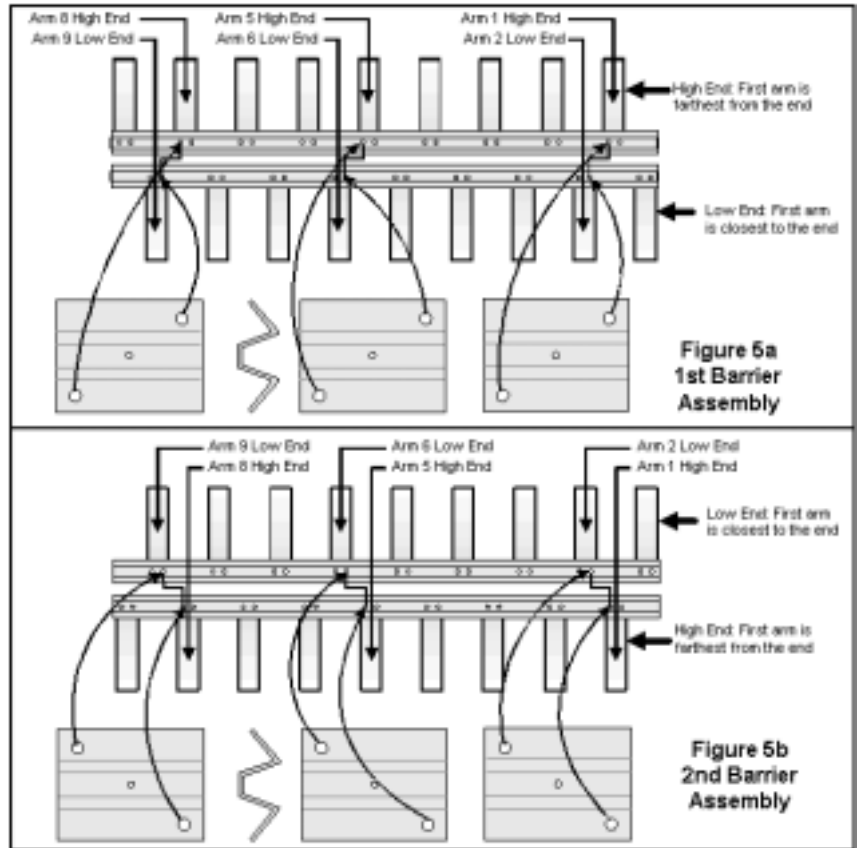


Figure 5 Attaching Barrier Angle Brackets

- Assemble the other two Barrier Arm Assemblies (Part #1 on EVD) exactly as shown in figure 5b and as described in steps 1 through 5 above.
- Remove and assemble the Barrier Cross Bar Support (Part #6 on EVD) and two Barrier Cross Bar Brackets (Part #7 on EVD) as shown in Figure 6, 7 and 8 at right.



Figure 6 Barrier Cross Bar Support

- Using the 5/16 – 18 X 3/4" bolts provided, bolt the Barrier Cross Bar Brackets to each end of the Barrier Cross Bar Support as shown above.



Figure 7 Barrier Cross Bar Bracket

- Connect the two Barrier Assemblies from Figure 5 together using the Cross Bar Support from Figure 8 above.

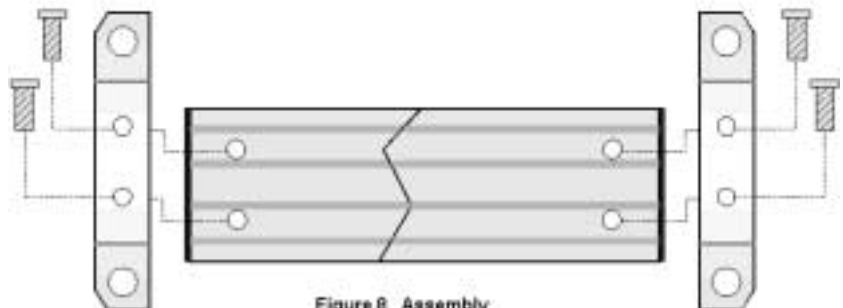


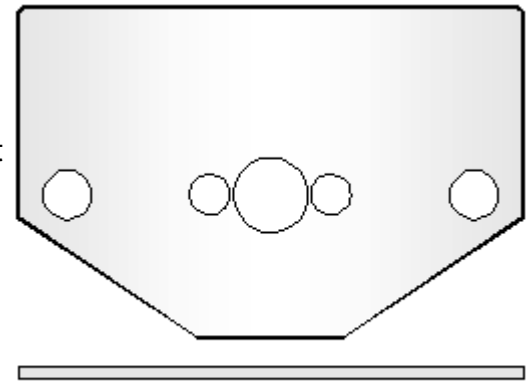
Figure 8 Assembly

- Locate the two Barrier Top Plates (Part #3 on the EVD) and shown in Figure 9 below.

- Use the Exploded View Drawing (EVD) for a guide to attach the two barrier sections with the Barrier Cross Bar Support.

- Viewed from the bolt side of the barrier arms, position one set of Barrier Arm Assemblies with the High End Barrier Section on the right side and at the bottom.

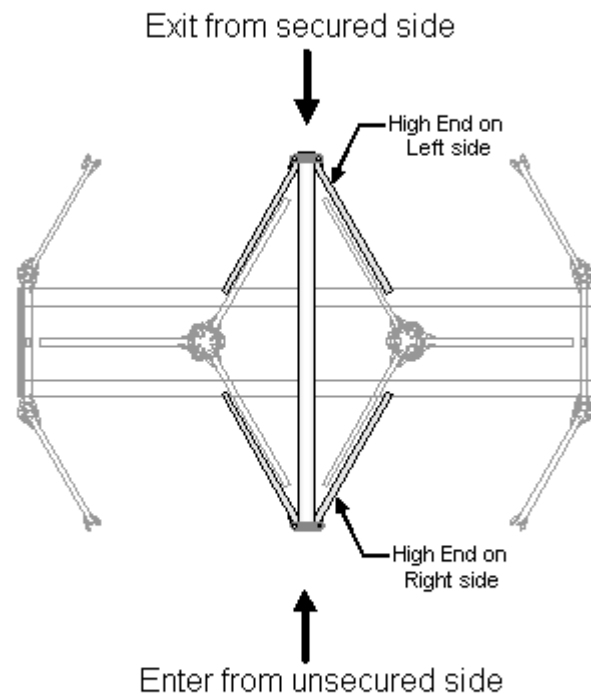
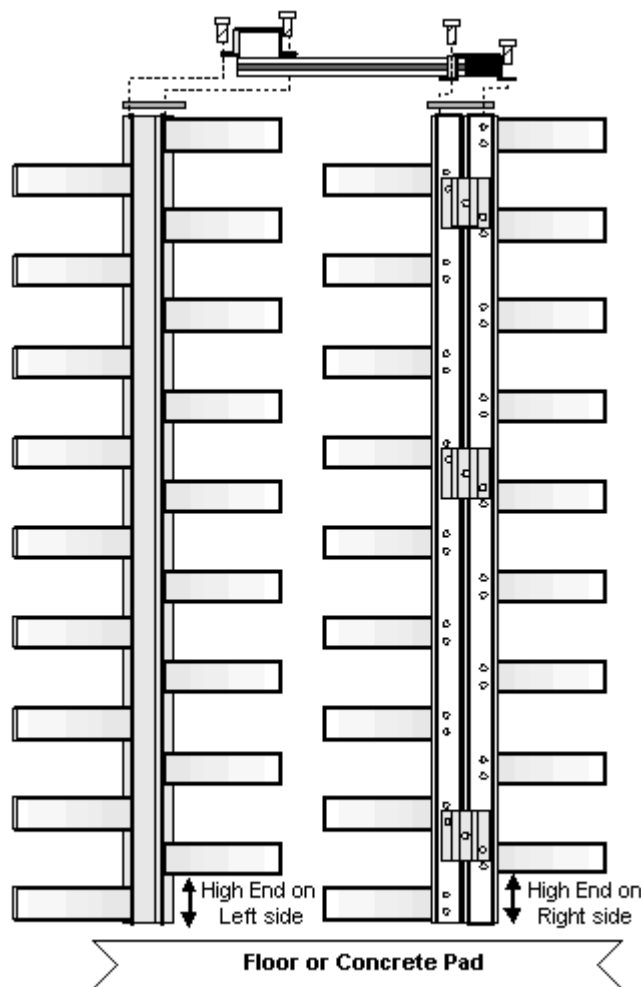
- At the top, sandwich the Barrier Top Plate between the top of the Barrier Arm Sections and the bottom of the Barrier Cross Bar Bracket that is assembled to the Barrier Cross Bar Support.



**Figure 9 Barrier Top Plate**

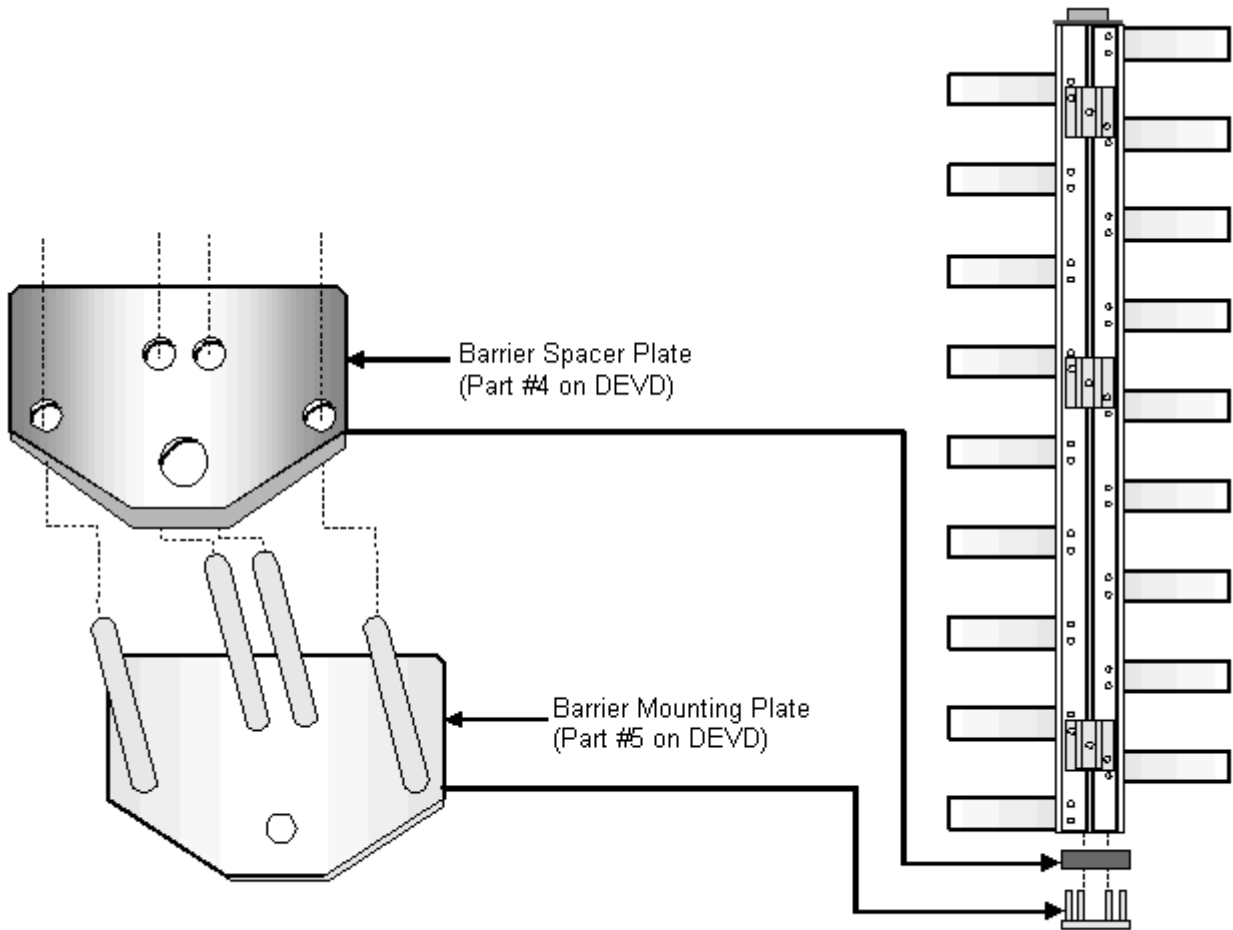
- Align the holes of the bracket with the threaded holes in the Barrier Assemblies and bolt together using the 1/2-13 X 3/4 " bolts provided. See figure 10 below.

- Attach the second set of Barrier Assemblies to the other end of the Barrier Cross Bar Support. This time, viewed from the bolt side of the arms, the High End Barrier Section will be on the Left. See figure 10 below.



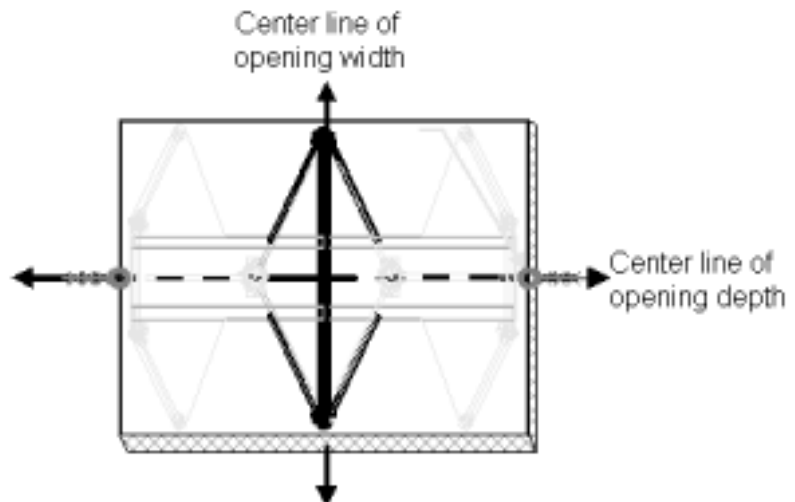
**Figure 10**

- Assemble Barrier Mounting Plate (Part #5 on EVD), Barrier Spacer Plate (Part #4 on EVD) and the Barrier Arm Assembly (Part #1 on EVD) as shown in figure 11 below.



**Figure 11**

- Position the completed Barrier Section in the center of the turnstile opening where it will be anchored. See figure 12 below.



**Figure 12  
Barrier Location**

## LEVEL AND PLUMB

- Drill and set anchor bolts as shown in Figure 13 below.

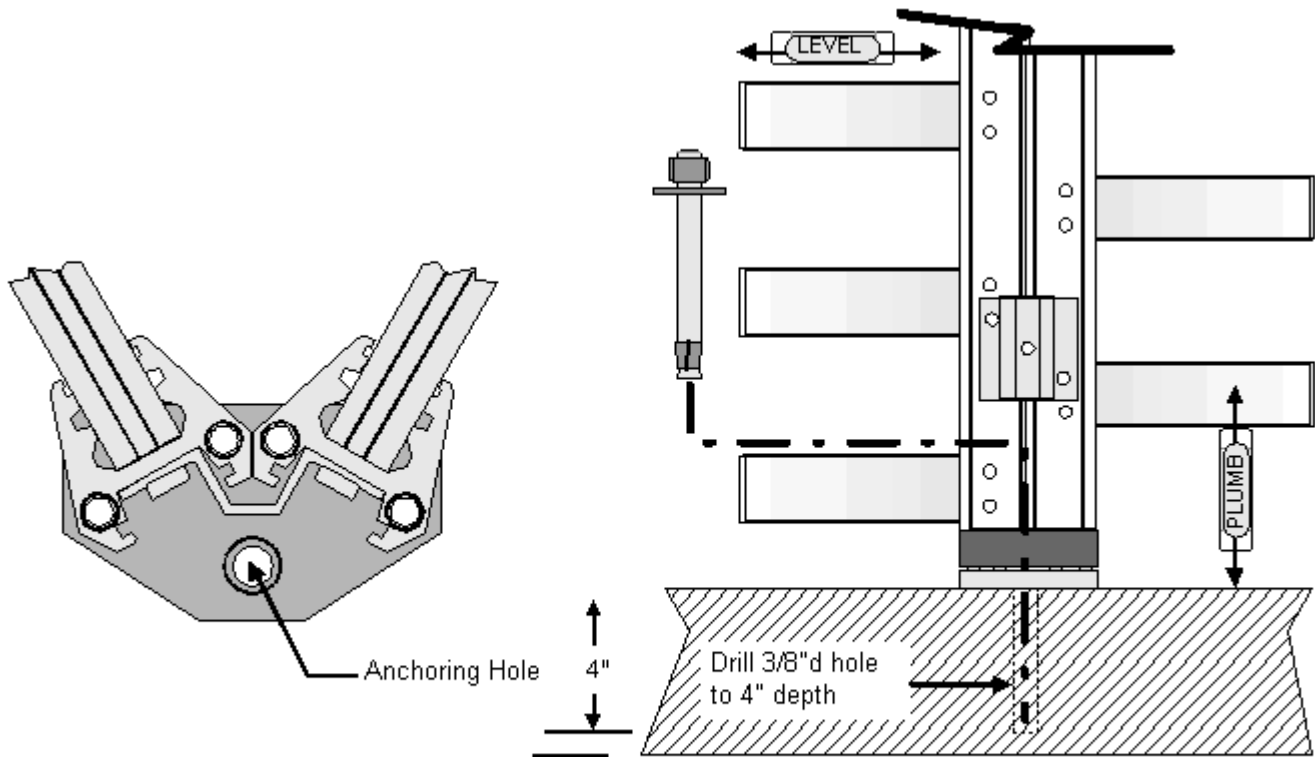


Figure 13 Anchor Barrier

## INSTALL THE PASSAGEWAY PANELS

- Remove A center passage panel (PART # 8 on EVD) and the two CPP mounting plates (PART #9 on EVD)

**NOTE:** The Center Passage Panel has a wire race outlet slot in the top horizontal member.

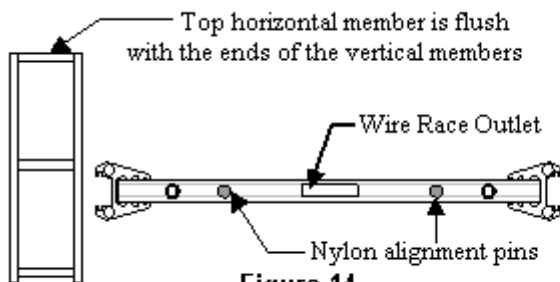


Figure 14  
Identify Center Passage Panel

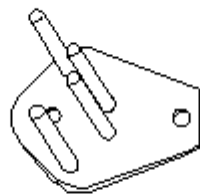


Figure 15  
CPP Mounting Plate

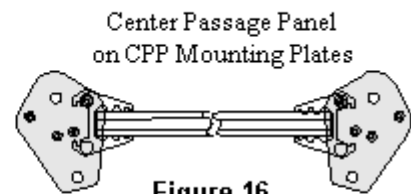
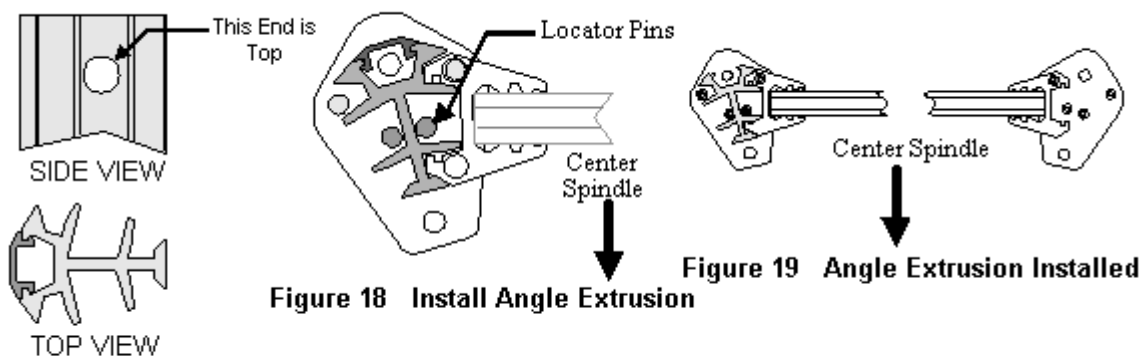


Figure 16  
Attach CPP Mounting Plate

- Position Center Passage Panel very close to where it will be anchored when the installation is finished.

**CAUTION:** During assembly of the passageway section one person should remain with the assembled sections to prevent the possibility of them falling over.

- REMOVE AND ATTACH ONE ANGLE EXTRUSION (PART # 10 on EVD)

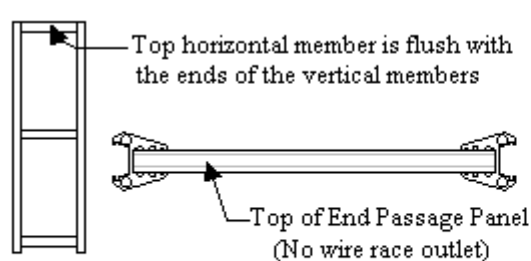


**Figure 18 Install Angle Extrusion**

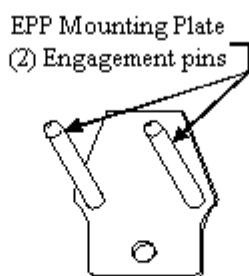
**Figure 19 Angle Extrusion Installed**

**Figure 17 Identify Angle Extrusion**

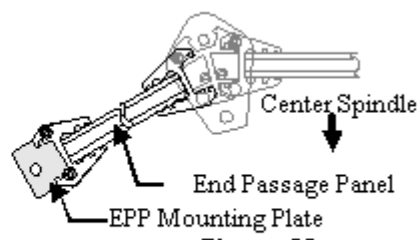
- Install the Angle Extrusion.
- Lift the Angle Extrusion to just higher than the mounting plate pins. Insert it into the back of the center panel as shown above and lower it down between the pins until it is flush with the top of the CPP Mounting Plate.
- REMOVE AND ATTACH ONE END PASSAGE PANEL (PART #11 on EVD) AND EPP MOUNTING PLATE (PART #12 on EVD)



**Figure 20 Identify End Panels**



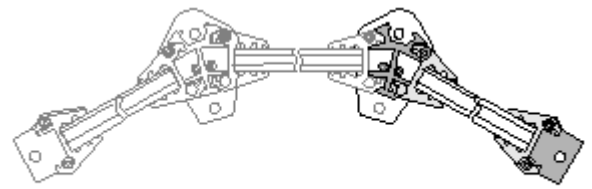
**Figure 21 Identify End Mounting Plate**



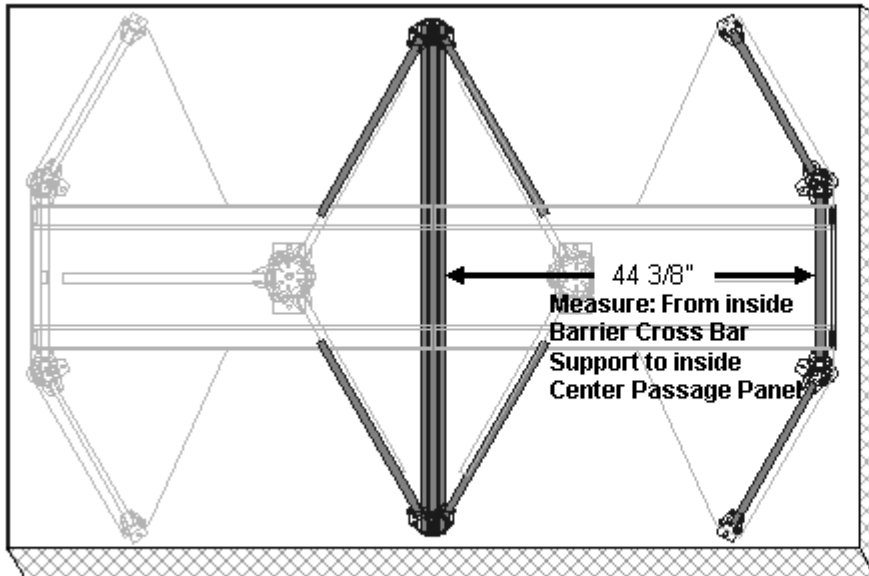
**Figure 22 Install Mounting Plate**

- Insert the engagement pins of the EPP Mounting Plate into the bottom vertical of End Passage Panel as shown above.
- Lift the End Passage Panel and EPP Mounting Plate above the engagement pin of the CPP Mounting Plate.
- Engage the back slot of the End Passage Panel with the Angle Extrusion and slowly lower the panel onto the pin until it is flush with the top of the CPP Mounting Plate.
- REMOVE AND ATTACH OPPOSITE SIDE ANGLE EXTRUSION (PART #10 on EVD), END PASSAGE PANEL (PART # 11 on EVD) AND EPP MOUNTING PLATE (PART #12 on EVD)

- Install same way as other side.
- Verify location of Passage Panels before installation of header assembly.



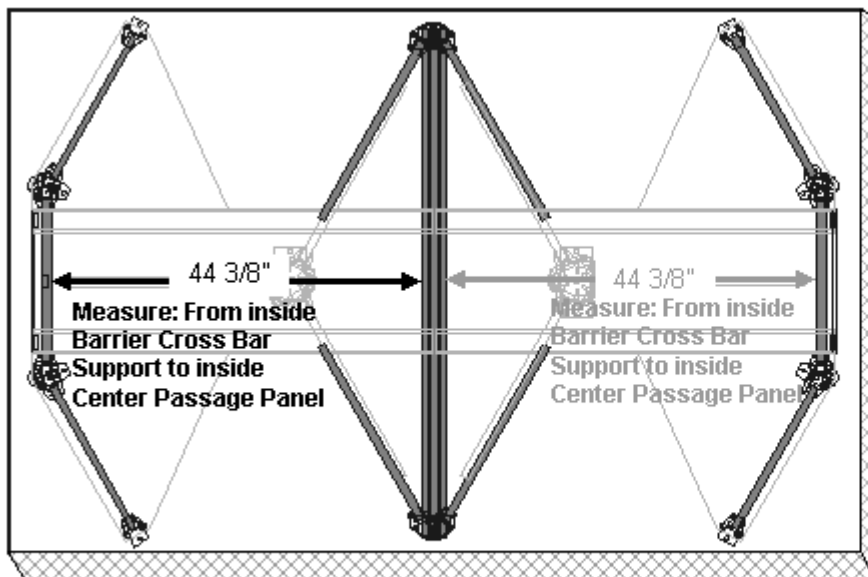
**Figure 23 Install other End Passage Panel**



CAUTION: Position passage panels only. DO NOT ANCHOR until instructed to do so later.

**Figure 24 Locate Passage Panels**

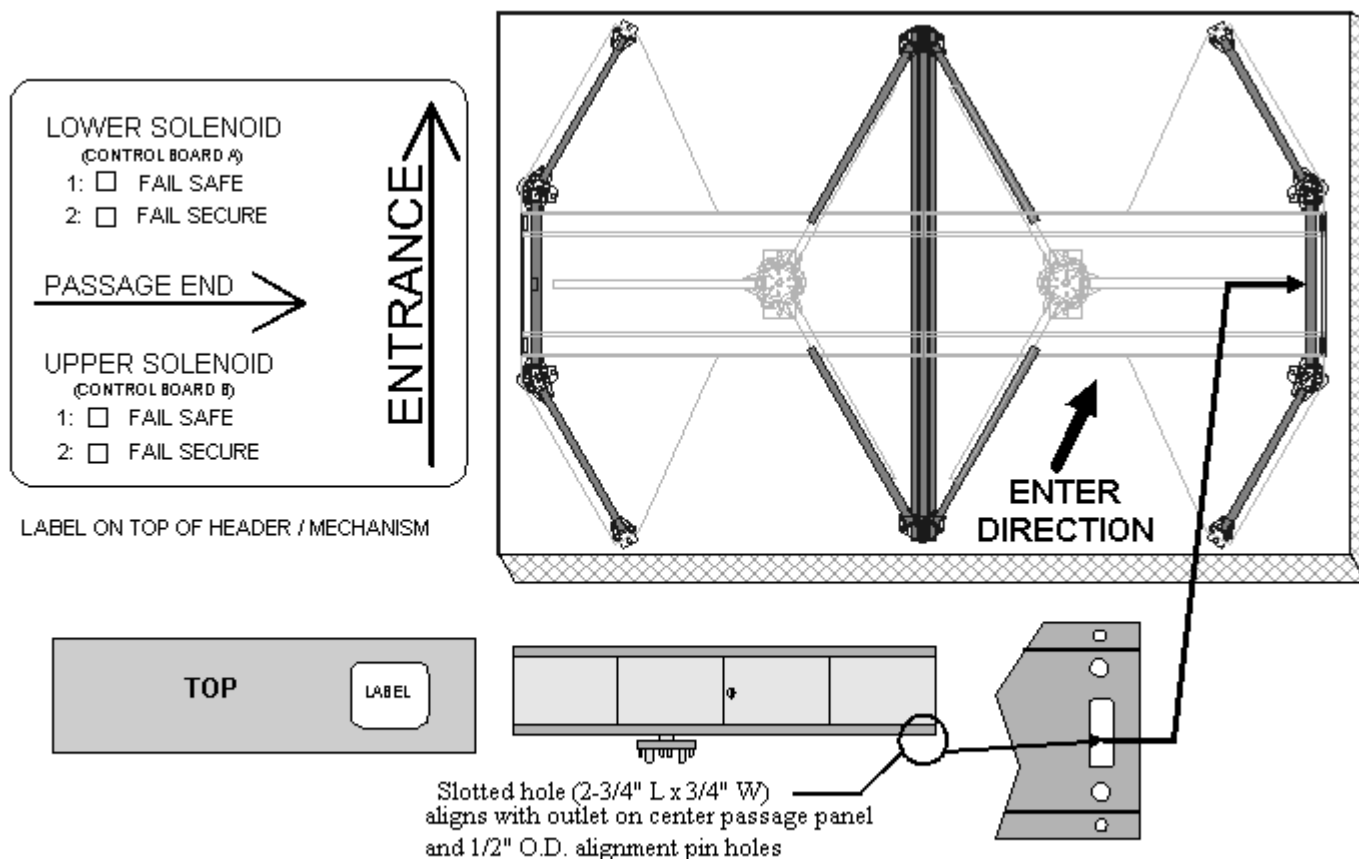
- The distance from the inside face of the barrier horizontal member and the inside face of the horizontal member of the center passageway panel should be 44 3/8".
- Assemble and locate the passageway for the other side of the barrier exactly the same as above starting with the Center Passage Panel (Part #8 on the EVD)



CAUTION: Position passage panels only. DO NOT ANCHOR until instructed to do so later.

**Figure 25 Locate Second Passage Panels**

- REMOVE AND INSTALL ONE OF THE HEADER / MECHANISM ASSEMBLIES (PART # 13 on EVD)
- The Header/Mechanisms have labels on the top to show which side of the Barrier they go to. See Figures 26, 27 and 28 below.



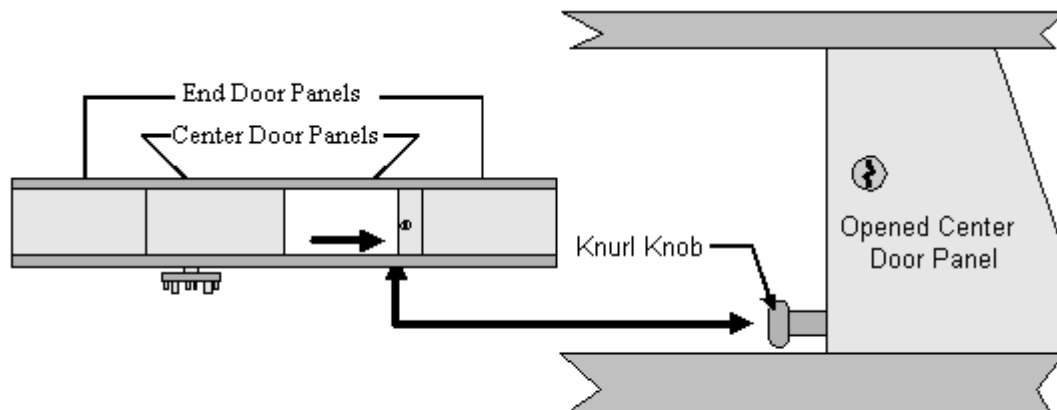
**Figure 26 Header/Mechanism Identification**

**NOTE:** Once the turnstile is fully assembled and anchored into place it will be necessary to secure the top of the unit to prevent excessive swaying when it is in use. If you need to drill holes into the ends or top of the Header/Mechanism to accomplish this, it may be easier to do that now while all surfaces of the header are accessible.

Now is a good time to prepare the header for conduit entry with power and control wiring. See **ELECTRICAL CONNECTIONS** near the end of this section.

- Identify which end of the header sits above the passageway panels.
- Look at the underside of the Header/Mechanism and find the end with a slotted hole in the sheet metal as shown in Figure 26 above. This end sits on top of the Center Passage Panel.
- Lift the Header/Mechanism above the barrier and passageway panels and set it down over the nylon locator pins of the Center Passage Panel and rest the other end on the Barrier Cross Bar Support.

- Secure the Header/Mechanism to the Center Passage Panel using the 5/16-18 x 3/4" bolts and washers provided. See Figure 27 below for access inside the Header/Mechanism here the bolt holes are.

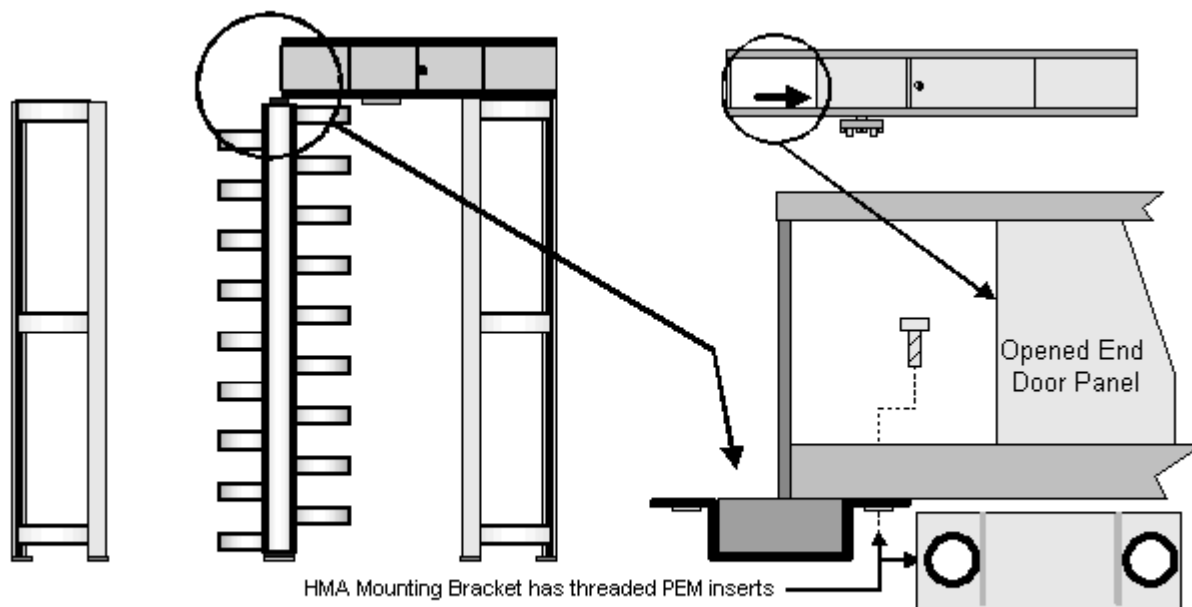


**Figure 27 Knurl Knob Identification**

**NOTE:** To gain access to the inside ends of the header cabinet;

1. Unlock the center door panels and slide them open as far as they will go.
2. Near the bottom of the door there is a rod with a knurl knob nut, rotate the nut toward the inside of the cabinet.
3. This will release the end door panels allowing you to slide them toward the center and access the mounting holes.

- On the Barrier side of the Header/Mechanism attach the (2) HMA Mounting Brackets (Part #14 on the EVD) as shown in Figure 28 below.



**Figure 28 Attaching First Header/Mechanism**

- ATTACH THE SECOND HEADER
- The second header attaches to the Barrier Assembly and other Passageway the same as the first Header/Mechanism. See Figures 29 and 30 below.

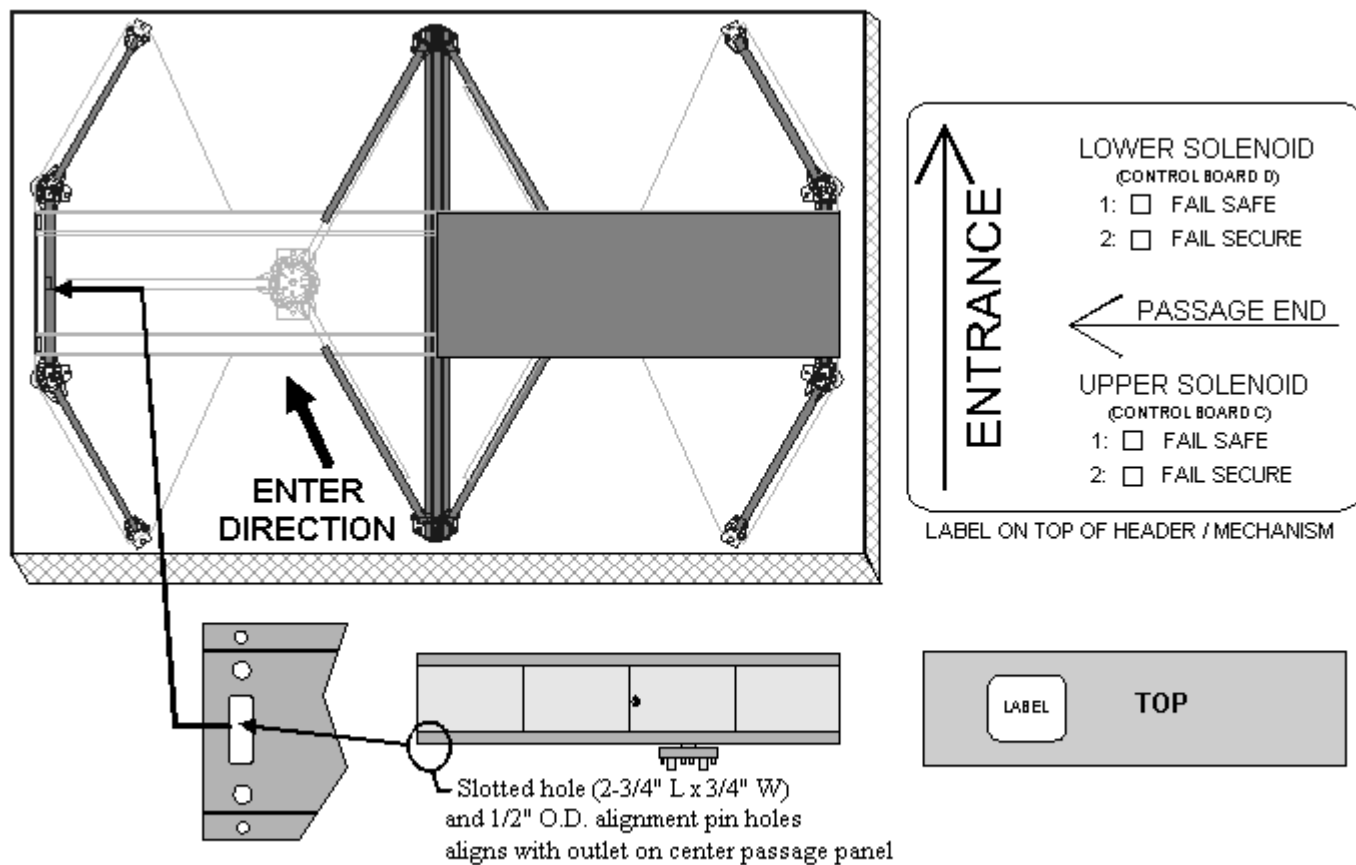


Figure 29 Header/Mechanism Identification

### INSTALLATION

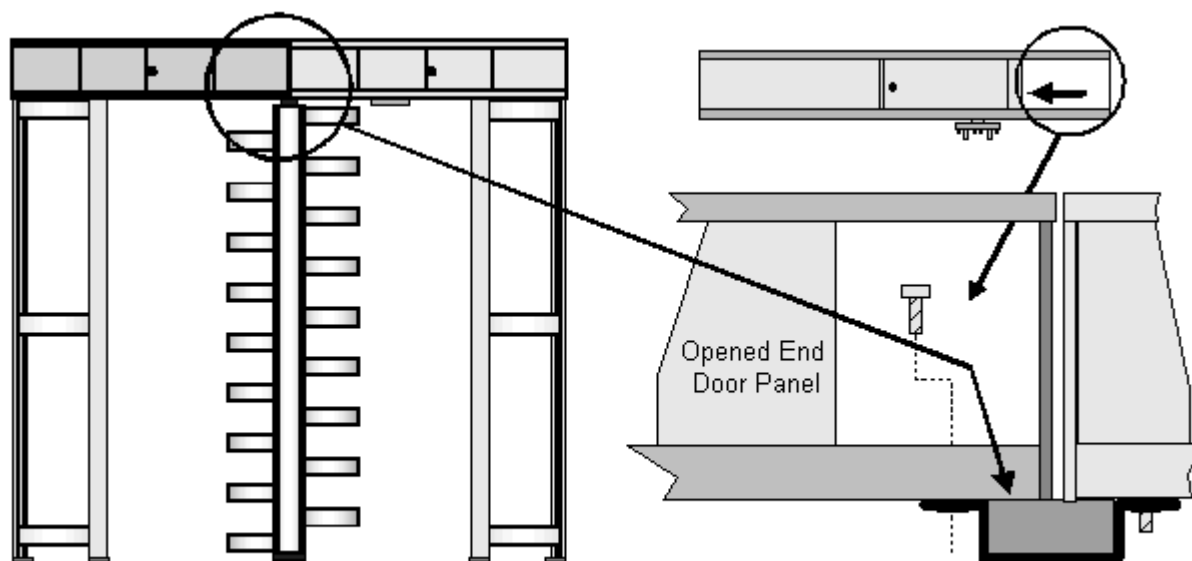


Figure 30 Attaching Second Header/Mechanism

- ANCHOR THE CENTER PASSAGE PANELS
- LEVEL and PLUMB the Center Passage Panel and anchor into place. (Do not drill holes for the end passage panels yet.)
- Note that the CPP Mounting Plates have two mounting holes each. Only one is needed to properly secure the panel.
- For a cleaner looking installation the outside anchor hole, see illustration below, should be used. However, if that location is not accessible for anchoring the inside hole can be used.

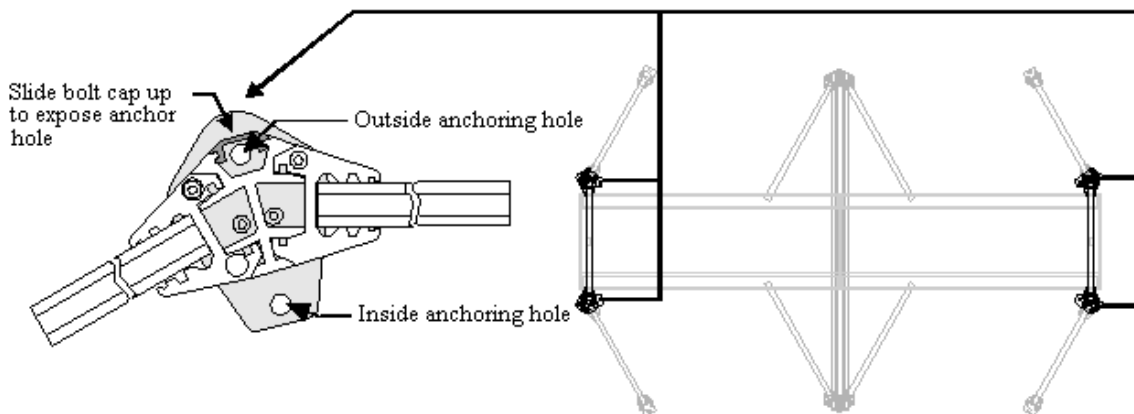


Figure 31 Anchor Center Passageway Panels

- PULL WIRES FOR THE STATUS INDICATOR LIGHTS
- Remove the Caps at the top of each End Passage Panel to expose the wire raceway.
- Rolled up inside the header on the passageway side are the wire cables for the status indicator lights.

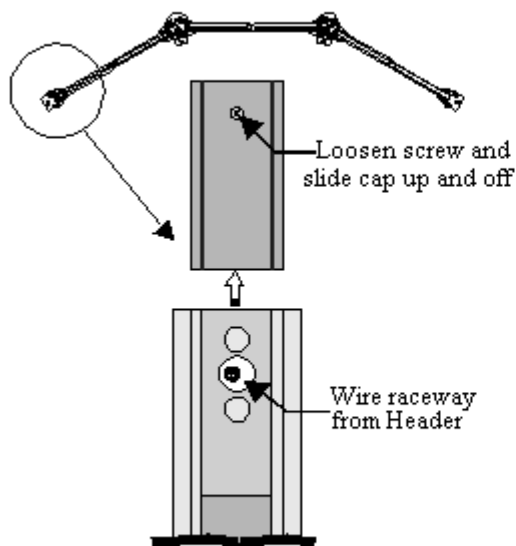


Figure 32 Wire Raceway

Figure 33 Cable Identification

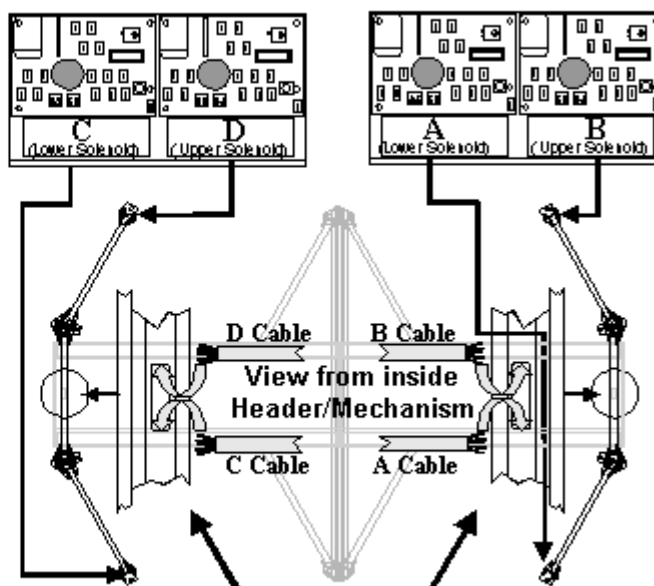


Figure 34 Cable Direction

- Starting from inside the Header/Mechanism, pull or push the appropriate cable to the status indicator lights to be wired as shown in Figure 33.
- Push the wire cable through the angle Extrusion as shown in Figure 34.

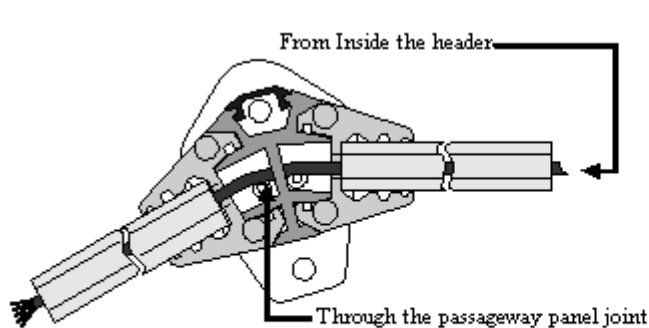


Figure 35 Push Cable Through

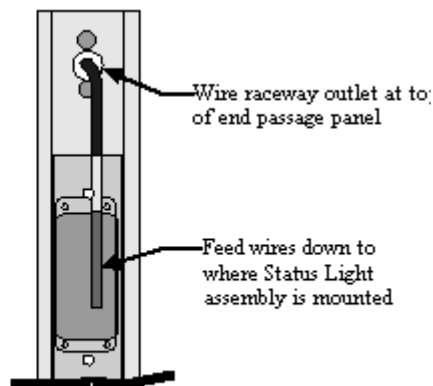


Figure 36 Cable Ending Point

- Push cable out of End Passageway Panel and feed down to Status Light location as shown in Figure 36.

**CAUTION:** Standard anti-static procedures should be observed when handling the Status Light Boards. It is recommended you ground yourself to the turnstile frame before handling the board. Remain in contact with the turnstile while handling the board.

- Remove the Status Light Cover using the #10-24 screws.
- Remove the Status Light assembly from the mullion using the #4-40 screws.
- Connect the wires to the terminal block on the Status Light Board as shown in Figure 23 above.

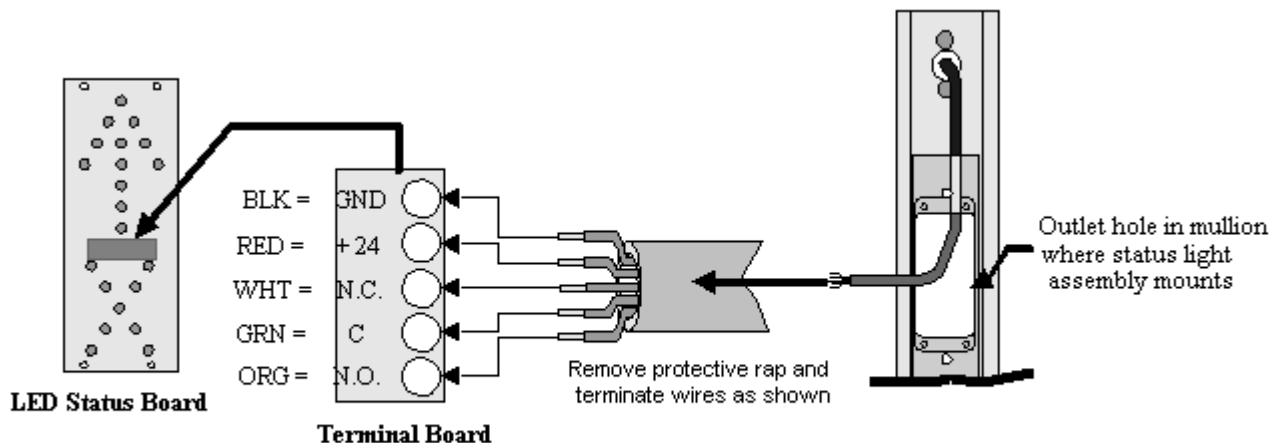


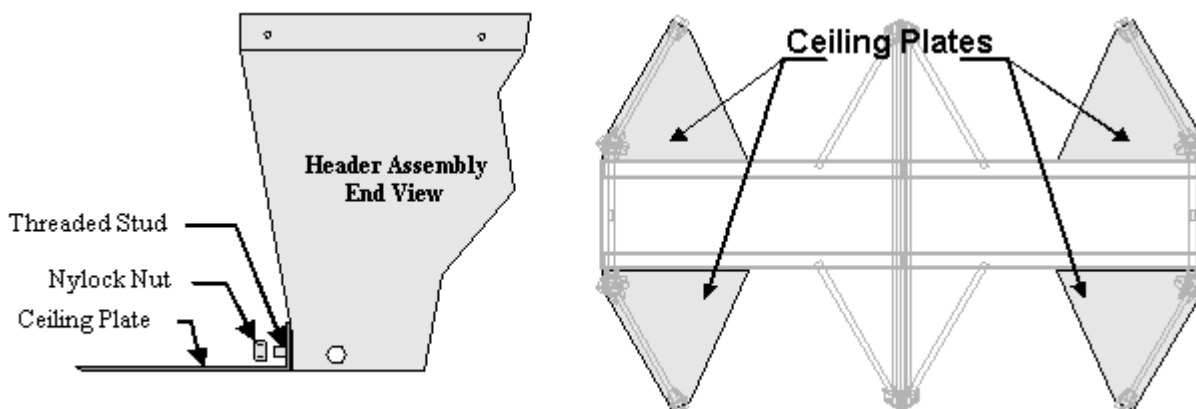
Figure 37 Status Light Wiring

- Attach the Status Light assembly to the mullion using the #4-40 screws.
- Install the Status Light Cover using the #10-24 screws.
- Reinstall the cap at the top of the End Panels.

- INSTALL THE PASSAGEWAY CEILING PLATES (PART #15 on EVD)

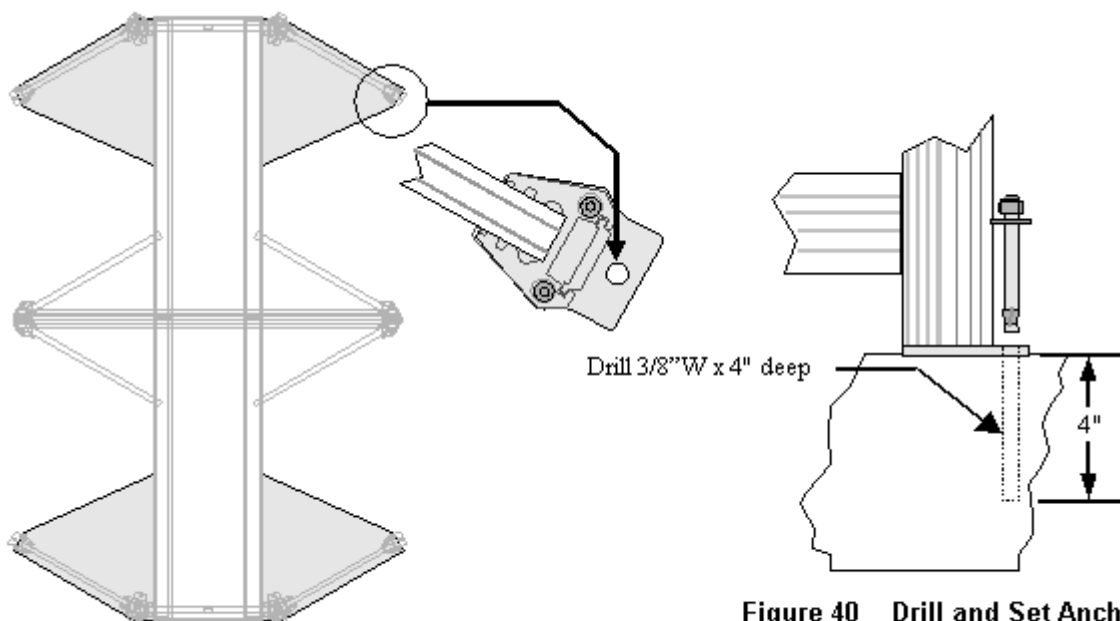
**NOTE:** The side of the ceiling plate with an edge protector will face toward the barrier.

- Slide the hole in the angle side of the plate over the threaded stud on the header and secure using the ¼-20 nylock nut provided.



**Figure 38 Attach Ceiling Plates**

- Secure the Ceiling Plate to the passageway panels using the ½-13 x ¾" bolts provided. (6 places)
- Repeat ceiling plate installation on opposite side of passageway.
- ANCHOR THE END PASSAGEWAY PANELS
- SQUARE and PLUMB the End Panels and anchor into place.



**Figure 39 Anchor End Panels**

**Figure 40 Drill and Set Anchors**

- INSTALL CENTER COLUMN AND SPINDLE ARM ASSEMBLIES
- Lift the Operating Mechanism to the install position.

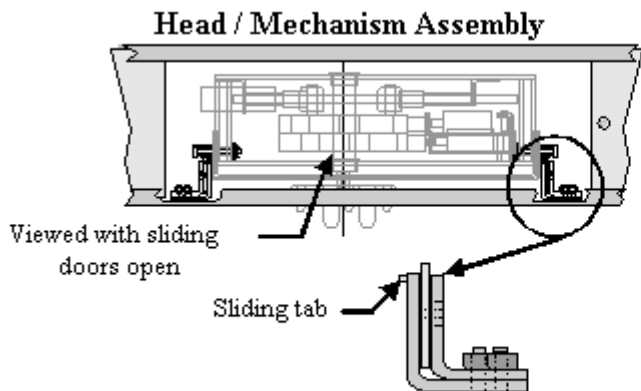


Figure 41 Raising the Mechanism

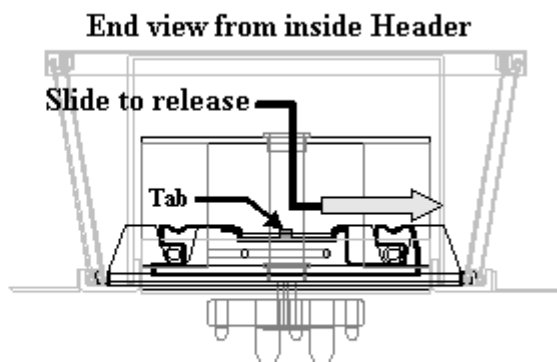


Figure 42 Release Mechanism Lock

- From inside the Header, slide the tab of the mechanism lock on both sides to release the mechanism.

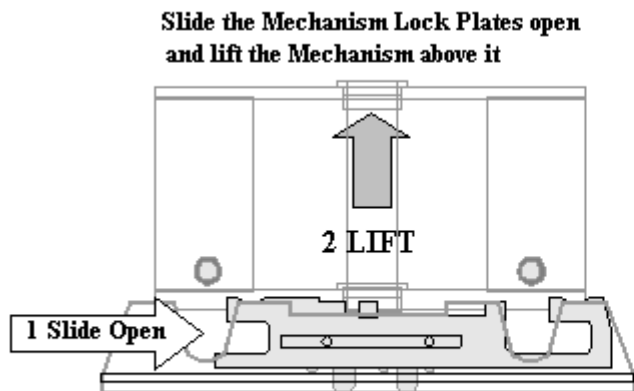


Figure 43 Release Lock and Raise Mechanism

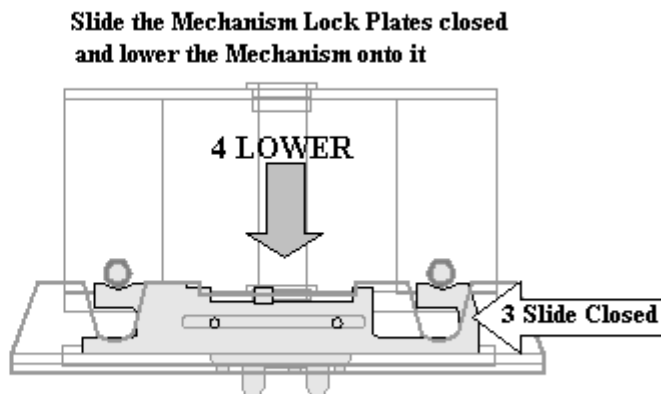


Figure 44 Place Mechanism on top of Lock

- From beneath lift the mechanism straight upward (two persons) until the slide bar tabs are accessible.
- Slide the tabs back to closed position and gently set the mechanism on it as shown in Figure 44.
- INSTALL CENTER COLUMN (PART #16 on EVD) and CC MOUNTING PLATE (PART #17 on EVD)

**Identify Center Columns:**  
(Viewed from public side)

**Low Arm Column**

is on the Right, the First "T-nut" is 10.5" from Top of Column

**High Arm Column** is on Left, the First "T-nut" is 15" from Top of Column.

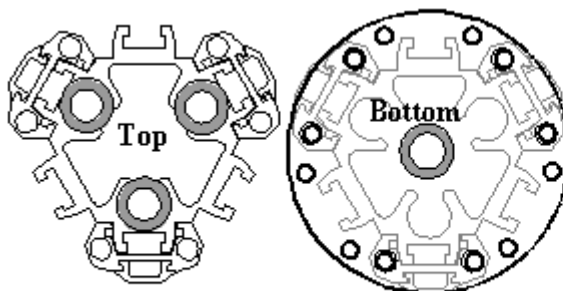


Figure 45 Identify Center Column

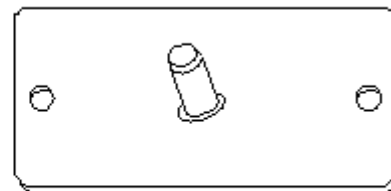
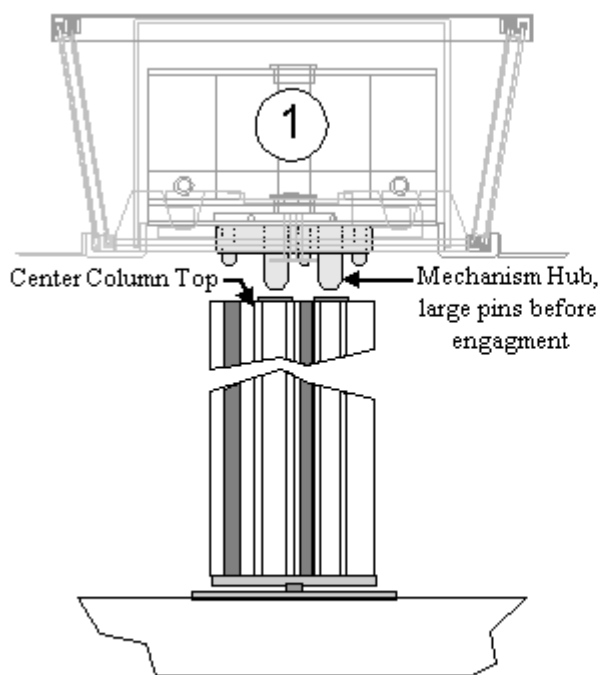
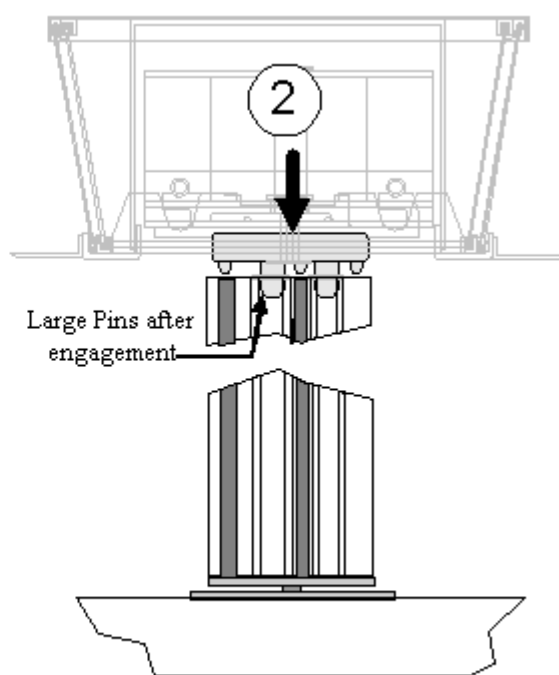


Figure 46 Identify CC Mounting Plate

- Insert the shaft of the CC Mounting Plate into the bearing on the bottom of the Center Column.
- Stand the Center Column up onto the CC Mounting Plate and position near the Mechanism Hub.
- Slide the Mechanism Hub up the Mechanism shaft until there is clearance for the Center Column to slide underneath.
- Slide the Center Column under the Hub, align the Center Column bushings with the large pins of the hub and slide the hub down the shaft engaging the pins into the bushings. There will be approximately 1/2" of engagement.



**Figure 47 Position Center Column**



**Figure 48 Engage Large Pins**

## INSTALL THE SPINDLE ARM ASSEMBLIES

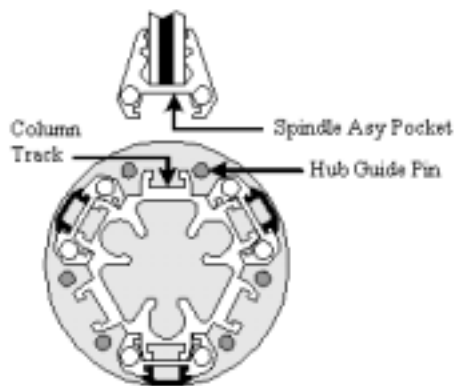
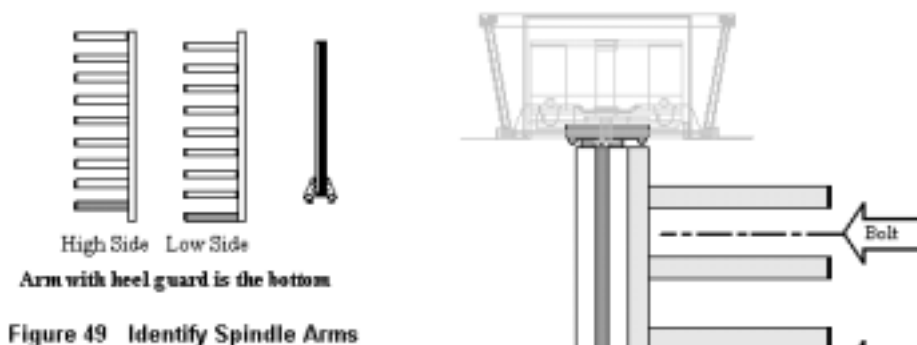
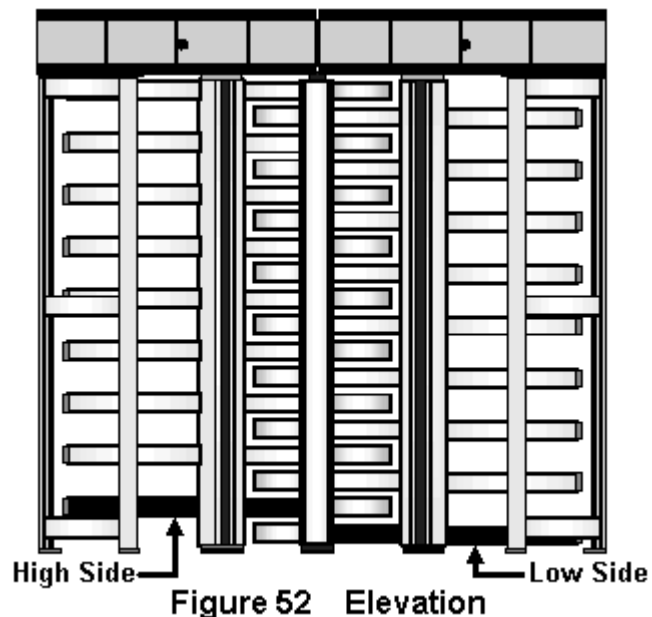


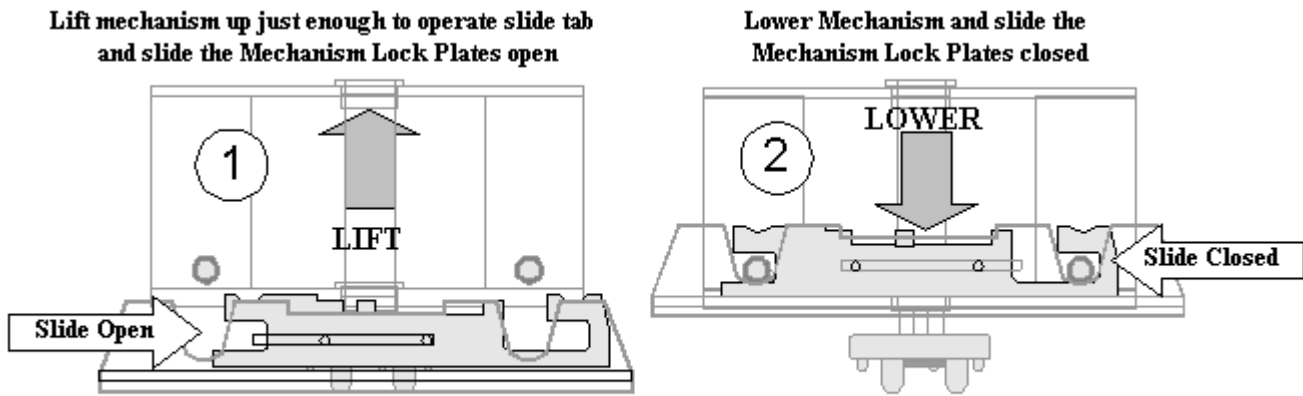
Figure 51 Secure Spindle Arms

- See figure 52 below for Low and High Side orientation.

1. Lift one of the Spindle Arm Assemblies to just above the guide pins on the Bottom Hub of the Center Spindle Column.
2. Engage the back pocket of the Spindle Arm Assembly onto the Center Column Track.
3. Lower the Spindle Arm Assembly onto the Hub Guide Pins.
4. Hold the Spindle Arm Assembly tight against the Center Column and bolt into place.
5. Use the 5/16 – 18 x 3/4" bolts provided. Secure in all 4 locations as indicated by the arrows above.
6. Bolting the top first will hold the Arm Assembly in place while the remaining bolts are being installed.
7. Repeat steps for the remaining two Spindle Arm Assemblies.
8. Lower and lock down the mechanism.
9. Lower the mechanism in the reverse manor of when it was lifted.

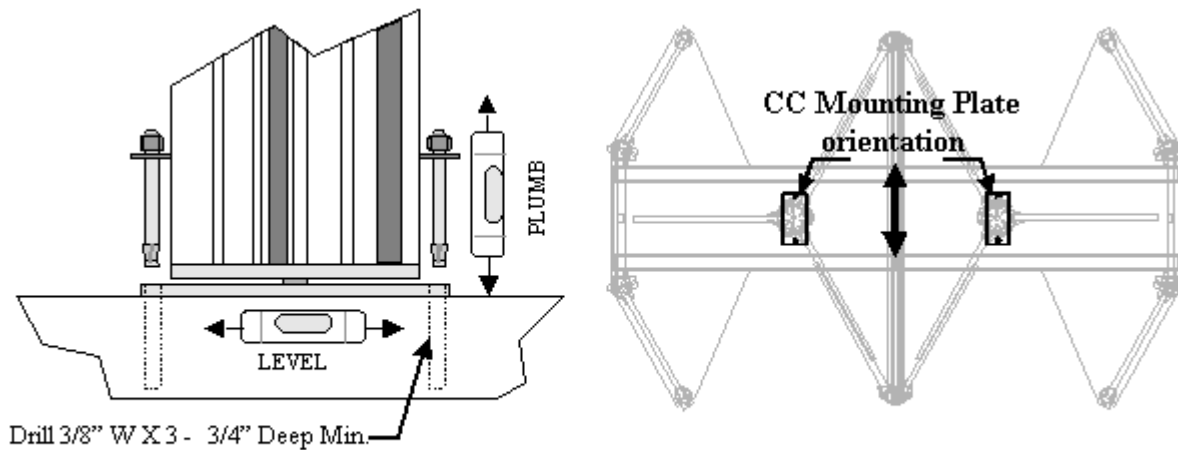
**CAUTION:** When lifting the mechanism to slide the tab for receiving, do not lift to high because the hub will disengage the center column.





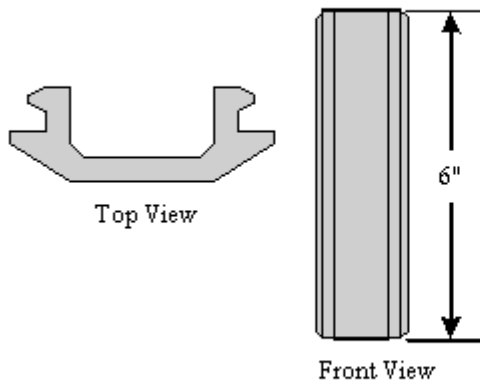
**Figure 53a Lower Mechanism and Lock**

- Insure that all the pins in the Hub are fully engaged into the Center Column and Spindle Arm Assemblies.
- Slide the mechanism lock plates to the locked position.
- Repeat steps 1 through 9 and lower the Mechanism on the other Spindle Arm Sections.
- SQUARE, PLUMB and Anchor the Center Column
- SQUARE and PLUMB the Center Column (Figure 53b below).
- Anchor the Center Column (Figure 53b below).

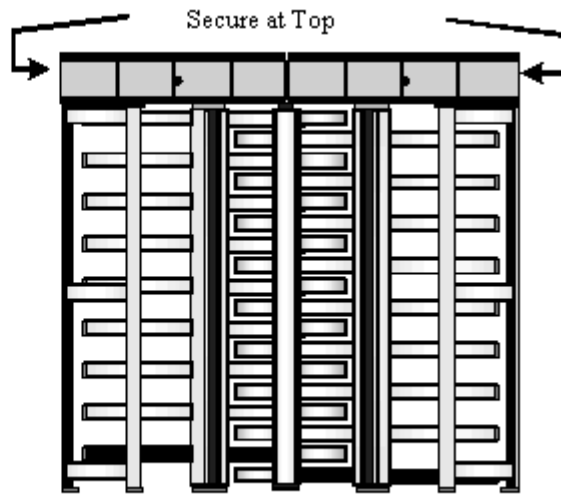


**Figure 53b Anchor the Center Column**

- INSTALL THE BOLT COVERS



**Figure 54 Bolt Cover**



**Figure 55 Secure Turnstile at Top**

- Use a rubber faced mallet and install one cap over all (24 places) of the spindle arm bolts.
- Secure to top of the turnstile to prevent top sway.
- The mechanical part of the installation is completed.

## 6 ELECTRICAL CONNECTION

- 120 VAC power connection
- Power for the turnstile must come into the header cabinet. Depending on the requirements of the site, it can either come in from the top or from one end of the cabinet.
- Where there are multiple turnstiles in a row it may be necessary to pass through from turnstile to turnstile with the power and control wires.

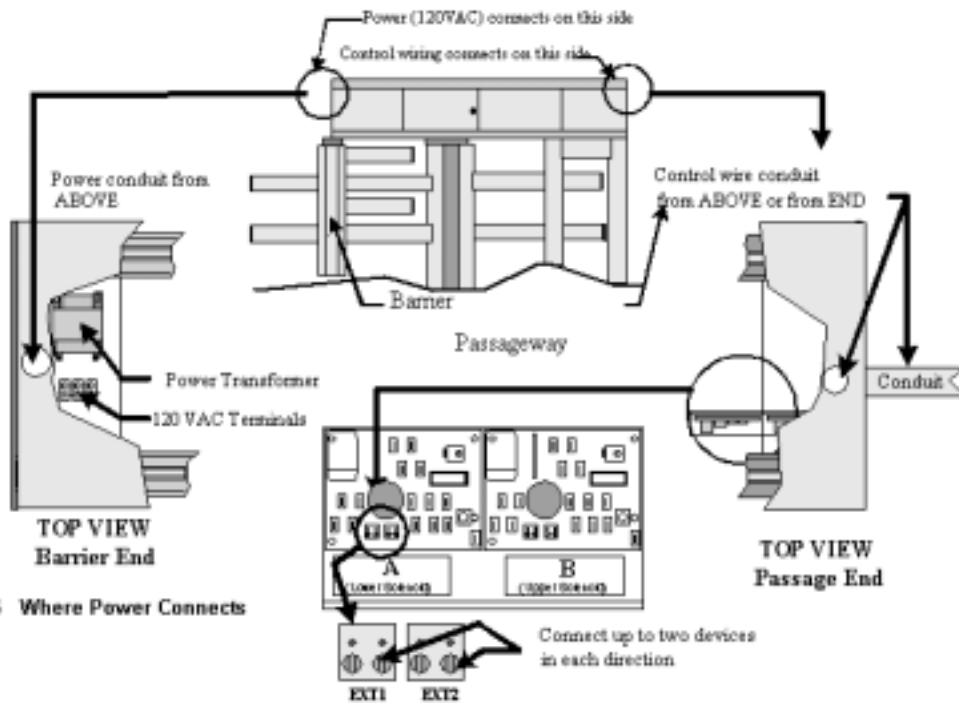


Figure 56 Where Power Connects

Figure 57 Where Controls Connect

**CAUTION:** When drilling into cabinet do not allow metal chips to fall on or near electrical components. Collect all chips and insure area is clean before applying power.

- Use watertight connections where entering the cabinet with conduit.
- Connect power to terminal block as labeled.

**CAUTION:** Standard anti-static procedures should be observed when handling the Turnstile Control Boards. It is recommended you ground yourself to the turnstile frame before handling the board. Remain in contact with the turnstile while handling the board.

- Connect card reader, pushbutton or other control contacts to either EXT1 or EXT2.
- Access control devices (Card Readers, Pushbuttons, etc.) must provide a momentary dry contact closure to activate the turnstile for one pass.
- Repeat for the other side of the turnstile.

## 7 FUNCTIONAL TEST

1. With all electrical connections made, turn power on and perform a functional test of the turnstile.
2. When power is applied the turnstile center spindle arms should be locked. Try to rotate the arms in either direction. They should not rotate!

### 2. TEST ROTATION

- a. On the control board of the direction of rotation to be tested first, push the START button.
- b. The solenoid that controls the direction being tested will release the locking pawl from the ratchet and allow the spindle arms to rotate.
- c. Push the turnstile arm sections in that direction, they should rotate for one cycle (120 degrees) and then re-lock automatically.
- d. Repeat a minimum of three times in each direction of rotation being tested.

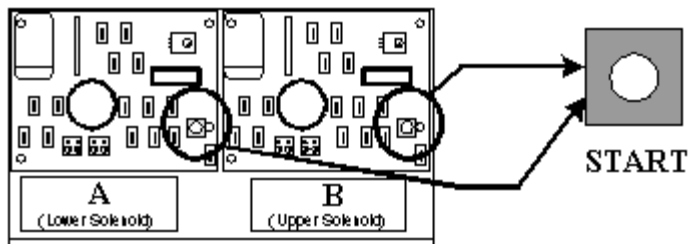


Figure 58 Start Button Location

### 4. TEST RELOCK TIMER

- a. Push the START button and the solenoid will activate the locking pawl. Wait ten seconds and the solenoid will de-activate the locking pawl.
- b. Push the START button and the solenoid will activate the locking pawl. Rotate the spindle arms approximately 10 degrees and hold in that position for more than 10 seconds, the solenoid will continue to activate the locking pawl.

### 5. TEST THE CENTERING MECHANISM

- a. Push the START button and rotate the spindle arms to just past  $\frac{1}{2}$  cycle. Stop the arms there and release them. They should rotate on their own and finish the cycle to the home position.

### 6. TEST THE ACCESS CONTROL DEVICE (S)

- a. Repeat the steps in number four above except use the access control device (Card Reader, Pushbutton, etc.) instead of the START button on the controller.

### 7. VERIFY THE STATUS LIGHTS ARE FUNCTIONING

- a. Verify that the red X status light is on before presenting the card.
- b. Present the card, the red X status light will turn off and the green arrow status light will turn on.
- c. Rotate the spindle arms to just past mid cycle and the green arrow status light will turn off and the red X status light turn back on.

8. REPEAT THE FUNCTIONAL TEST (STEPS 1 THROUGH 7) FOR CONTROLLERS C AND D ON THE OTHER TURNSTILE.

## CONNECTION DIAGRAM: FULL HEIGHT SECURITY TURNSTILE

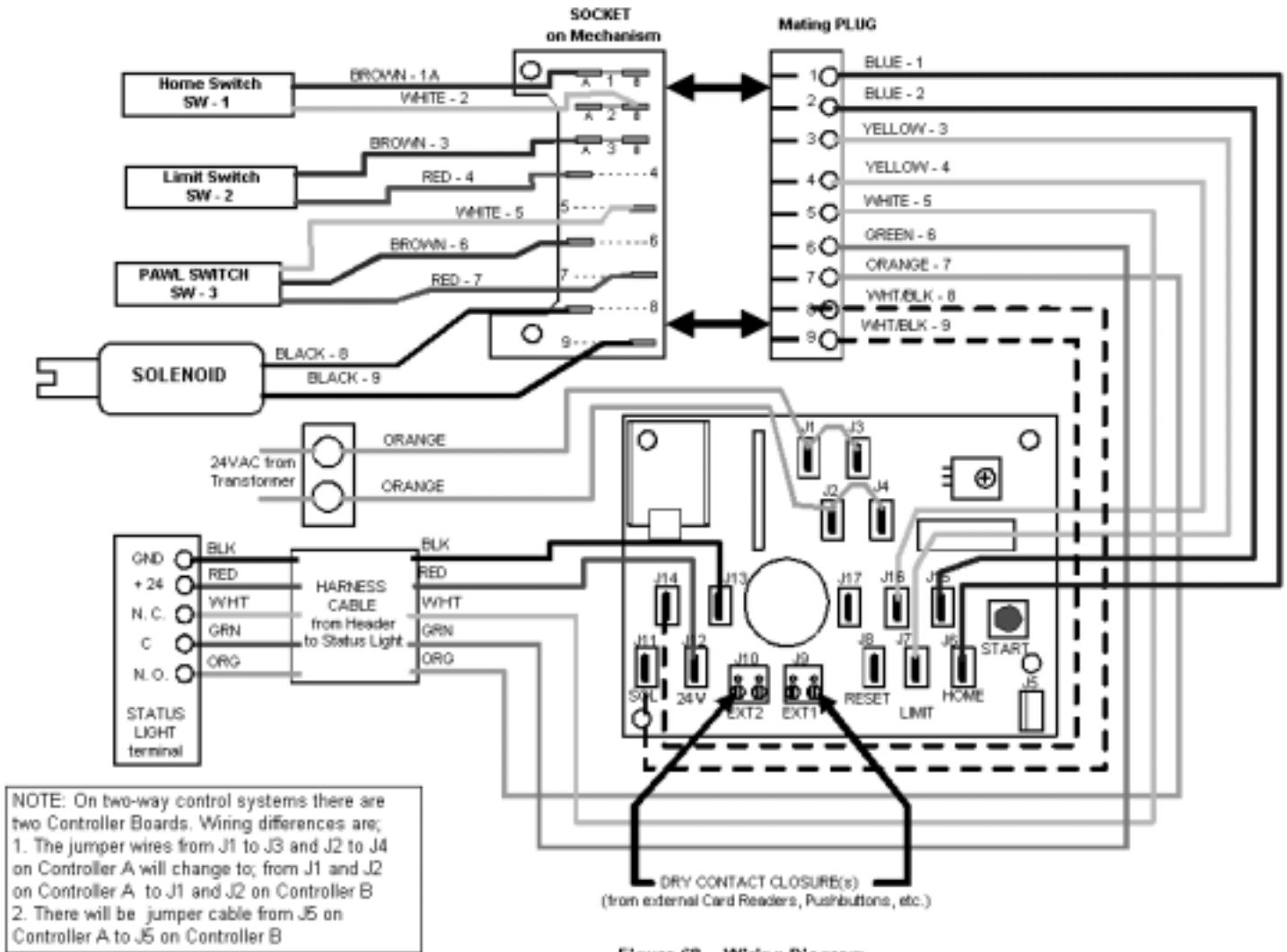


Figure 60    Wiring Diagram

## 8 FAIL-SAFE/FAIL-SECURE CONFIGURATION

- Disconnect the solenoid linkage (A) from the Solenoid by pulling out solenoid pin (X).
- Rotate Solenoid to line up with solenoid linkage (B) and reconnect Solenoid using solenoid pin (X).
- Disconnect the Pawl load spring (C) from the pawl pin (Y).
- Reconnect pawl load spring (C) to pawl pin (Z).
- On the Control Board that controls the Solenoid being changed, slide switch (S) to opposite position that it is in.

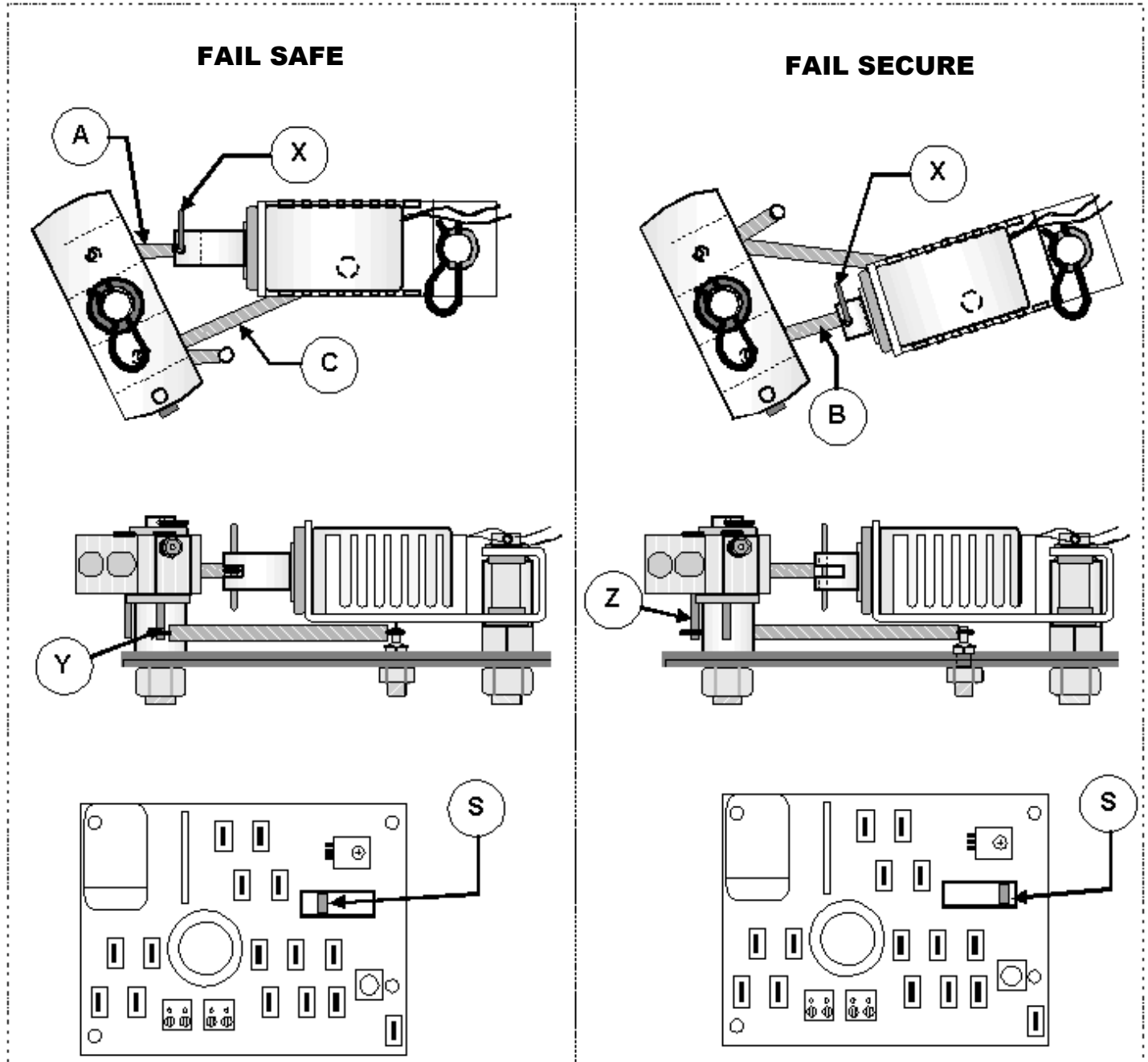


Figure 59 Conversion

## 9 SERVICE AND MAINTENANCE

- All bearings are self-lubricating and do not require servicing or lubrication.
- Clean exterior aluminum and polycarbonate panel using a non-abrasive cloth with warm water and a mild detergent.
- Annually check solenoid plungers for wear. If excessive wear is observed replace solenoid.
- Annually check mechanism self-centering and speed control cylinder by observing while rotation the spindle section.
- Annually check for loose bolts or nuts.

### MECHANISM PARTS

Dwg #	Part Number	Description
1	315 4453 011	Solenoid Assembly
2	315 4383 001	Locking Pawl Assembly
3	315 4385 900	Shock Absorber
4	315 4396 910	Detent Centering Spring
5	315 4396 920	Detent Shock Spring
6	315 4397 910	Pawl Return Spring
7	315 4397 920	Solenoid to Pawl Spring
8	315 4417 001	Detent Cam Roller
9	315 4420 900	Hitch Pin Clip
10	315 4455 011	Detent Cam Assembly
11	315 4530 500	Ratchet and Bushing Assembly



mechtronics

©2006 Aigis Mechtronics

1124 Louise Road, Winston-Salem, NC 27107-5450

Tel: 336.785.7740 Fax: 336.785.7744

Data subject to change without notice

100 0115 001 AIG 06/06

Printed in U.S.A.