

Builder Products Magazine names ChannelPlus one of the top 100 new product picks in the nation.

For the third consecutive year, ChannelPlus has been chosen from over 2000 new products introduced in four of the leading building magazines serving the residential marketplace. These magazines include Builder, Remodeling, Custom Home and Building Products.



“Interestingly, it is generally not the high-profile, big budget manufacturers who win the awards although they do grab some. It is normally the cutting edge products serving the residential and light commercial marketplaces that readers want to learn more about!” says Carol Weinman of Building Products.

Vice President of Sales and Marketing, Tom Paterniti says, “It really shows how much hard work everyone here at ChannelPlus puts into every product we make.”

Tom Paterniti named to CEDIA Manufacturers Council. “I am honored to have the opportunity to participate in the CEDIA manufactures council”

said Tom Paterniti, Vice-President of Sales and Marketing, “CEDIA is a driving force that continually shapes and supports our industry. Many of the industry standards and innovations in home theater are because of its members and volunteers that are the catalysts of CEDIA’s continued growth and commitment.”

New Sales Representative joins Multiplex.

Paul Stone of Paul Stone Sales Co., Inc. will represent both the OpenHouse and ChannelPlus product lines in the mid-west territories of Indiana and Kentucky. Paul can be reached at 317-957-1444 or fax 317-957-1148 or pstone@indyweb.net.

Product News ChannelPlus DA-500A



ChannelPlus has introduced a new DA-500A. The new amplifier replaces the highly regarded DA-500. Offering a total redesign in style and circuits, the DA-500A brings a new look and cooler running design with greater EMI rejection.

ChannelPlus -In stock & available now! DA500A

- 18dB of gain with one in, one out
- New updated look that runs cooler and has more EMI rejection
- New power supply that is more robust and reliable

DA520A

- Bi-directional amplifier
- 20dB of forward and 0dB of reverse gain

OpenHouse H619



OpenHouse now has a versatile phone interface module utilizing the RJ45 interface jack. The new H619 has a 110 punch down input and 12 RJ45 jacks wired in parallel. It offers distribution of four lines to 12 locations.

OpenHouse-In stock & available now! H619

- RJ-45 Telephone interface hub (4lines x 12 telephone locations)
- 110 punch-downs
- 12 RJ-45 connectors for output

Product Update

Discontinued Product	Replacement Product	Date Available
DA500	DA500A	In stock
DA510	TBA	TBA
DA520	DA520A	In stock
DA512	TBA	TBA
DA1000	DA1000A	TBA
3116	TBA	TBA
1538	DA506BID	April
5114	5415	In stock
5116	5415	In stock
5214	5415	In stock
5216	5415	In stock
5314	5415	In stock
5316	5415	In stock
2600 series	TBA	TBA
9500cat-cam	NONE	NONE

International / Export News

ChannelPlus -In stock & available now!
DA-500AEXP (NPS)

- Replaces the DA-500EXP or DA-500NPS

OpenHouse-In stock & available now!
H291UK

- 4 outlet AC accessory

Product Update

Discontinued Product	Replacement Product	Date Available
5114PAL	5415PAL	Current
5116PAL	5415PAL	Current
5214PAL	5415PAL	Current
5216PAL	5415PAL	Current
5314PAL	5415PAL	Current
5316PAL	5415PAL	Current
DA-1002	DA-1002A	TBA
DA-502	DA-500A NPS	Current
3116EXP	TBA	TBA
1548 series	DA-506BID NPS	Q2

Trainings & Tradeshows

This year factory training will be available in two locations.

April 24th Brea, CA

May 23rd Brea, CA

June 8th Atlanta, GA

Training is one day and includes lunch. Topics include RF basic design, trouble-shooting and structured wire basics. For information on the classes please visit www.ChannelPlus.com

CEDIA Regionals

April 1 & 2 Chicago, IL

May 6 & 7 Stamford, CT

Tradeshows

ISC West

April 4, 5, 6 Las Vegas, NV

We will be located in the

Linear booth #2716.

International CEDIA Regional

May 9, GoldCoast, Australia

May 20, UK

Success Stories!

CEDIA Regionals

Tom Paterniti, Vice President of Sales and Marketing was ecstatic with the outcome of the recent CEDIA Regional Training seminars in Dallas, Texas. All six seminars were highly successful, with an average attendance of 38 to 40 people.

We would like to thank the CEDIA members and CEDIA staff for an excellent record setting regional!

International

Zailyn Prada, Corporate Trainer, reports a very successful first time technical training seminar for our Mexico distributors TECSO-MULTIMEDIA in Mexico City. Zailyn's fluency in Spanish was a real asset to the training.

A special thanks to the TECSO staff for their great organization and the hospitality offered to Zailyn during her stay!

Letters to Larry



Dear Larry,

I purchased a 3445 Whole-House Video Distribution System. After installing it I found that the channels I wanted to use, 85, 87 and 89, were dirty from my CATV cable. The problem only occurs

when the CATV is connected. I purchased an LPF-750, low pass

filter, that helped somewhat but the picture is still far from acceptable.

I also have a problem with the distribution panel combining channels (channel with the ghost of another channel) when the CATV is connected. I have already tried replacing the distribution panel and adding a DC blocker in the CATV line but it didn't help. What can I do to correct these problems?

Dear Installer,

Do the "ghosts" appear on the CATV, if the incoming line is connected to one TV? If so, I would suspect that you are receiving a bad signal and recommend contacting your cable provider. If not, the cable company may be giving you a very "hot" signal, which is overdriving the antenna amp. Try a variable attenuator or a few fixed attenuators to determine what level of signal eliminates the problem.

It sounds as if the low pass filter problem you are experiencing is due to utilizing the wrong filter. The LPF 750 eliminates channels 120 and up. I recommend that you use the LPF 470 to eliminate channels 65 and up.

Letters to Larry are taken from actual letters we receive on our web site. If you have technical questions please contact us at info@channelplus.com or call our technical support line toll free at 800-999-5225 M-F 8am-5pm(PST).

Tech Tip Video Distribution

Video distribution systems take on several variations, including RF, line level and even wireless. At Multiplex Technology, we excel at designing and manufacturing top-of-the-line products for RF distribution. Every RF distribution system needs four fundamental components: amplification, modulation, distribution and control. Before deciding which products to use, we must determine what our needs for a complete system are by answering general design questions.

First, find out how many rooms need a television or coax cable run. Secondly, decide how many sources will be used (i.e. DVD, VCR, cameras, satellite receiver). Thirdly, discover whether the customer has CATV or an antenna. And finally, find out if IR control for the sources is desired (IR can be an optional upgrade in the future).

For our purpose in the diagram below, the customer has a satellite receiver, VCR and front door camera that must be distributed through out the home with IR control for up to eight televisions.

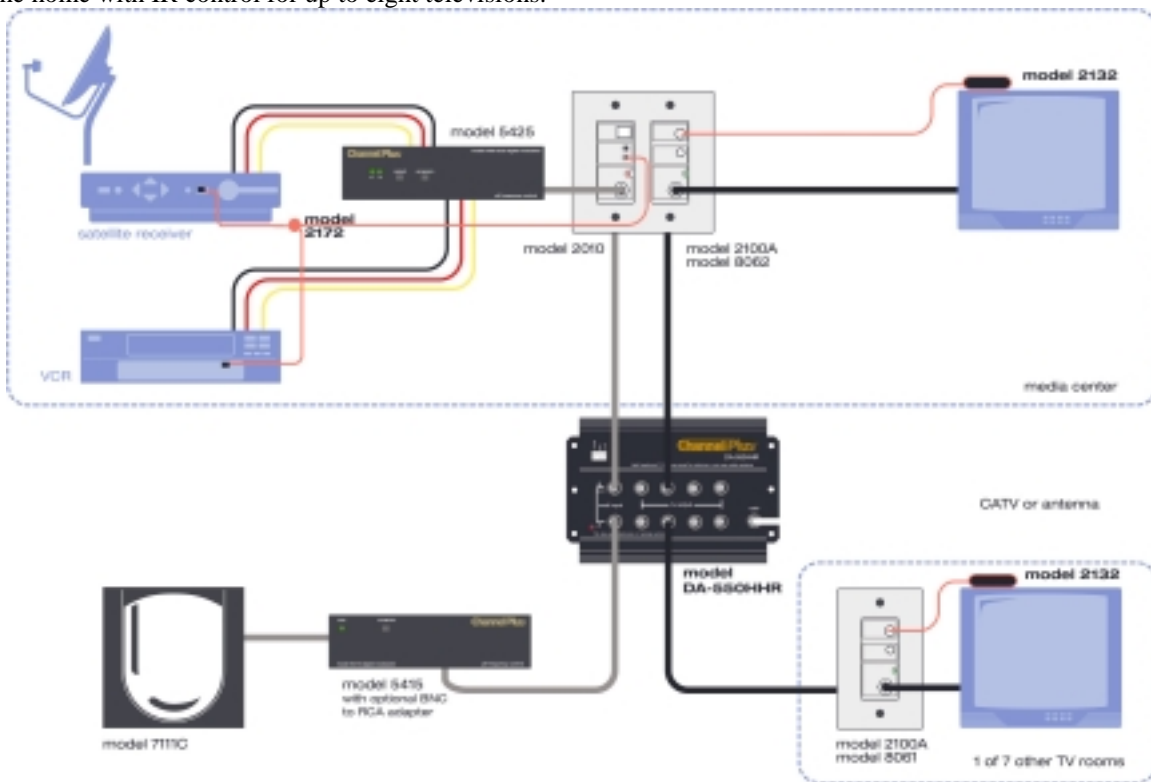

The distribution panel has inputs for up to two modulators. Each modulator allows a separate channel for each source to be created. The panel also has an input for CATV or an antenna. All inputs are amplified and split out for up to eight televisions 150 feet away. An IR target is located at each television location and an IR emitter at each source location for complete IR control.

The result? We have given the customer the ability to see their front door camera, VCR and satellite receiver at every TV in their home with IR control.